



CLEANLINE™ GEAR DRIVES & MOUNTED BEARINGS

Solutions for Pharmaceutical, Meat, Poultry and
Produce Processing & Washdown Applications.

Hub ³ ™ (Hub Cube) Advantages	O-2 to O-3
CleanLine™ Features	O-4 to O-7
CleanLine UltraPlus™ & Pharmaceutical	
Selection	O-8
Hub ³ ™ (Hub Cube) Stainless Steel Worm Gear Drives	O-9 to O-13
Hub ³ ™ (Hub Cube) Stainless Steel Bevel Gear Drives	O-14 to O-18
Hub ³ ™ (Hub Cube) Stainless Steel Helical-Bevel Gear Drives	O-19 to O-20
Hub ³ ™ (Hub Cube) Stainless Steel Accessories	O-21 to O-23
Stainless Steel Mounted Bearings	O-24 to O-25
CleanLine Plus™	
Thermoplastic Composite Mounted Bearings	O-26 to O-27
Stainless Steel Bearings and Ratings	O-28
Thermoplastic Composite Housing Load Ratings	O-29
Mounted Bearing Accessories	O-30 to O-31
Cleanline Plus™ Bevel Gear Drives	O-32 to O-33
CleanLine™	
Gear Drives	O-34



The Hub City Advantage



Raising Pharmaceutical, Meat, Poultry and Produce Processing Solutions to a Higher Power!

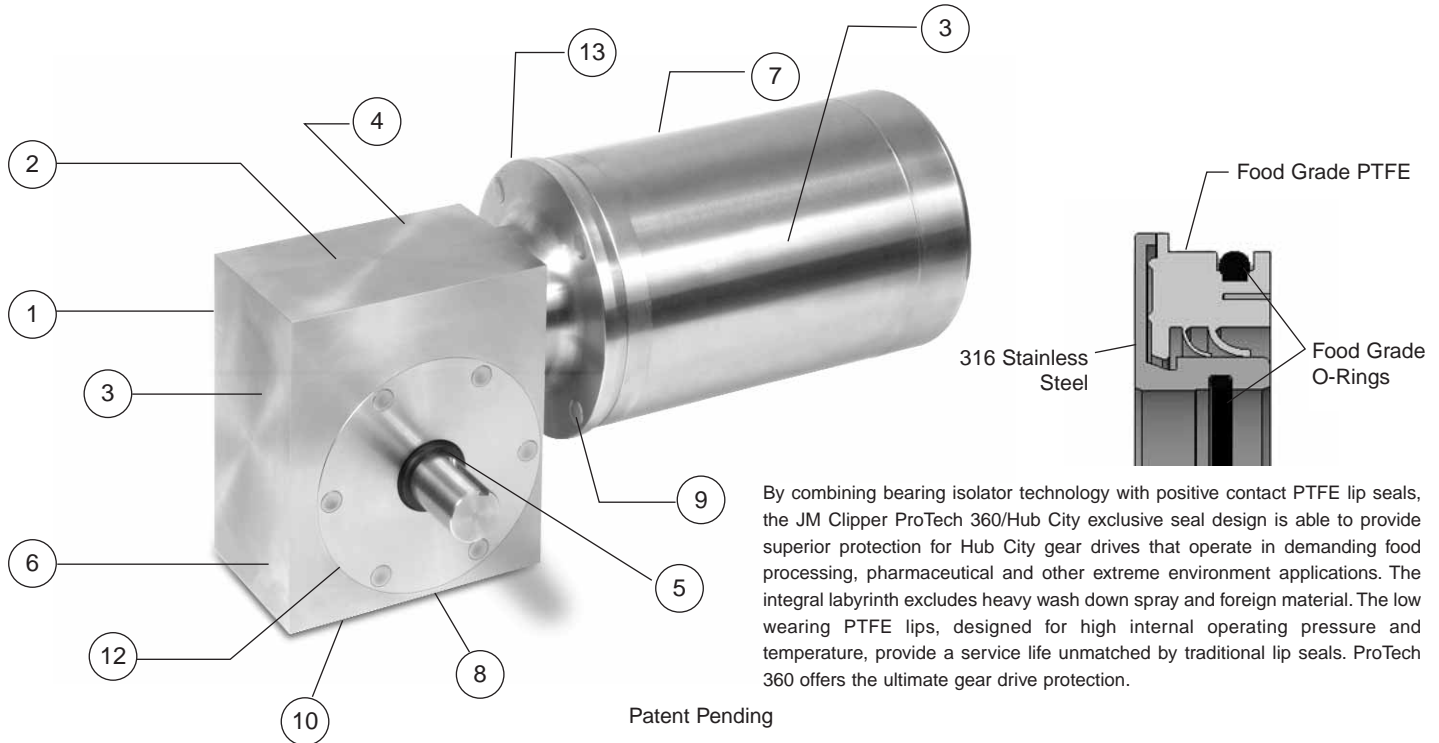

By combining bearing isolator technology with positive contact PTFE lip seals, the JM Clipper ProTech 360/Hub City exclusive seal design is able to provide superior protection for Hub City gear drives that operate in demanding food processing, pharmaceutical and other extreme environment applications. The integral labyrinth excludes heavy wash down spray and foreign material. The low wearing PTFE lips, designed for high internal operating pressure and temperature, provide a service life unmatched by traditional lip seals. ProTech 360 offers the ultimate gear drive protection.

Patent Pending

- | | |
|--|--|
| <ul style="list-style-type: none"> ① 316 Stainless Steel Housing, Shafting and Hardware (Plated Non-motorized Integral Gear Input Shafts): <ul style="list-style-type: none"> • Provides superior corrosion resistance ② Cleanline UltraPlus and Pharmaceutical Design Enhances Ease of Cleaning: <ul style="list-style-type: none"> • All exterior surfaces uninterrupted and machined • Contoured interfaces • No protrusions • No undercuts • No ribs ③ Reducer/Motor Oversized Identification, Configuration, and Operating Data: <ul style="list-style-type: none"> • Micro-embossed in the housing/frame for permanent retention • Elimination of bacteria growth supporting protrusions • Will not trap food particles or dirt ④ Sealed Housing Design-Non-Vented: <ul style="list-style-type: none"> • Will not ingest liquids and foreign material during operation or washdown ⑤ JM Clipper ProTech 360/Hub City exclusive seal design: <ul style="list-style-type: none"> • Bearing Isolator technology excludes high pressure wash down spray and foreign material. • PTFE lip seal technology retains oil • Retains lubricant regardless of gear drive mounting position • Sealing surface is internal, no shaft wear • All components meet USDA/FDA requirements • Superior gear drive protection in hostile food processing applications • Low wear PTFE lips, designed for high internal operating pressure and temperature, provide extended seal and gear drive service life • Enhances ease of cleaning | <ul style="list-style-type: none"> ⑥ Permanently Lubricated for the Service Life of the Drive With USDA/FDA Compliant Lubricant: <ul style="list-style-type: none"> • Excellent ageing and oxidation stability • Broad service temperature range • Physiologically inert and without taste or smell ⑦ Motors: <ul style="list-style-type: none"> • Stainless steel • Totally enclosed non-vented (TENV) with rear integral non-protruding conduit box (1/4, 1/3, 1/2, 3/4 and 1 horsepower) • Total enclosed fan cooled - TEFC (1-1/2, 2, 3, and 5 horsepower) • Conduit opening for customer connection is easily relocated to 12:00, 3:00, 6:00, and 9:00 o'clock positions • C-Face non footed design • Smooth uninterrupted exterior surfaces enhances ease of cleaning • Suitable for inverter-duty applications ⑧ Rebuild for Life Longevity Program ⑨ Installation/Service Friendly NSF/3-A Compliant Fasteners ⑩ Computer Aided Designed Elevated Operating Temperature (Above 160°F) Assists in Eradicating Bacteria ⑪ HACCP Compatible ⑫ O-Ring Sealed Bearing Carriers ⑬ Sealed Motor to NEMA Frame Interface |
|--|--|



The Hub City Advantage

The Hub City stainless steel Hub³™ design goes beyond basic corrosion resistance, by providing a machined unobstructed, contoured exterior surface. The exterior is free of ribs, undercuts and protrusions that do not support washdown, cleaning and sanitary conditions. The geardrives are configured such that all exterior surfaces self drain, do not entrap soil, foreign material or contain areas that support the breeding of bacteria, fungi, mold and or other microorganisms. All exterior surfaces are smooth and easily cleaned allowing for cleaning in place or manual cleaning processes.

The design of this superior product evolved from facility inspections and design input from a number of major food, meat, produce, and pharmaceutical processors. The acquired data was integrated with "Hygiene requirements for the design of meat and poultry processing equipment," NSF/ANSI/3-A 14159-1-2002. These resources, combined with Hub City's years of design and application experience in these industries, provide a drive that specifically meets the requirements of the processing industries and FDA/USDA/NSF National Sanitation Requirements. Several typical industrial applications requiring high degrees of sanitation and hygiene or severe environmental conditions are listed as follows:

- Food Handling and Processing including:
 - Poultry and Meat
 - Seafood and Fish
 - Cereal and Grain
 - Produce
 - Baking
 - Beverage
- Pharmaceutical Industry
- Chemical Processing Industry
- Petroleum Processing Industry
- Tobacco Industry
- Carwash Industry
- Mixer Industry
- Pump Industry

Stainless steel Hub³™ geardrives, manufactured with 316 stainless steel housings and shafting, provide superior corrosion resistance to most types of chemical corrosives

and washdown chemicals. The exterior stainless steel surface texture is 70 microinches R_a. Configurations with a smoother surface texture (near mirror finish) are also available, consult the factory for further information.

Stainless steel Hub³™ geardrives utilize non-vented housings with high-pressure seals designed to be easily cleaned, expel and exclude foreign material and are resistant to ingestion of liquids during pressurized washdown. The seal material is non-absorbent and capable of withstanding elevated operating temperatures.

Stainless steel Hub³™ geardrives are factory lubricated, for the application service life of the unit, with food-grade lubricant conforming to the demands of USDA H1 regulations. The ingredients used in the formulation of this lubricant are on the FDA list of allowable substances, as specified in the Guidelines of Security CFR 212, section 178.3570.

Stainless steel Hub³™ geardrives are supported by industry-identified accessories. These accessories increase functionality, reduce bacteria and microorganism growth, and enhance ease of cleaning. Accessories are listed as follows:

- Clearance Spacers
- Shaft Protectors
- Hollow Bore Output Sleeve Protectors
- Universal Base Kits
- Torque Arm Brackets
- "C" Flange Adaptor Kits

Hub City stainless steel Hub³™ geardrives are part of the Hub City "Rebuild for Life Longevity Program". This program ensures that the customer is only required to purchase the stainless steel geardrive one time. When the unit has reached it's service life it can be returned to the factory and refurbished for the current cost of a similar sized cast iron drive. The refurbished unit carries the same factory warranty as a new unit.



CleanLine™ Pharmaceutical Premium Solutions



Hub³™ Stainless Steel Worm Gear Drives

Features:

- ◆ Four Sizes: 1.75" CD, 2.06" CD, 2.625" CD & 3.25" CD
- ◆ Surface Polished to a Near Mirror Finish
- ◆ Permanently Lubricated for Application Service Life of the Drive with USDA/FDA Compliant Lubricant
- ◆ Sealed Non-Vented Housing
- ◆ High Pressure Dual Lip Seals Configured for Severe High Pressure & Chemical Washdown Environments
- ◆ 316 Stainless Steel Housings & Shafts
- ◆ Packaged with LEESON Washguard® All-Stainless Motors
- ◆ Rebuild for Life Longevity Program
- ◆ Patent Pending



Hub³™ Stainless Steel Bevel Gear Drives

Features:

- ◆ Five Models: M3, 165, 175, 65 and 66
- ◆ Surface Polished to a Near Mirror Finish
- ◆ Permanently Lubricated for Application Service Life of the Drive with USDA/FDA Compliant Lubricant
- ◆ Sealed Non-Vented Housing
- ◆ High Pressure Dual Lip Seals Configured for Severe High Pressure & Chemical Washdown Environments
- ◆ 316 Stainless Steel Housings & Shafts
- ◆ Rebuild for Life Longevity Program
- ◆ Patent Pending

Introducing: Hub³™ Stainless Steel Helical-Bevel Gear Drives

See page O-19 for details.



CleanLine Ultra Plus™ Stainless Steel Mounted Bearings

Features:

- ◆ 304 Stainless Steel Housing
- ◆ 440 Stainless Steel Rings and Balls
- ◆ 302 Stainless Steel Flingers and Retainers
- ◆ Factory Filled with USDA/FDA Compliant Lubricant
- ◆ Polished Surface Finish to 32R_a μin
- ◆ Bore Sizes Up to 1.9375

CleanLine UltraPlus™ Ultimate Solutions

Hub³™ Stainless Steel Worm Gear Drives

Features:

- ◆ Four Sizes: 1.75" CD, 2.06" CD, 2.625" CD & 3.25" CD
- ◆ Designed to be Compliant with NSF/ANSI/3-A 14159-1—2002
- ◆ Surface Finish Machined to a R_a of 70 μ in
- ◆ Factory Filled with USDA H1 Lubricant for Application Service Life of the Drive
- ◆ Sealed Non-Vented Housing
- ◆ High Pressure Dual Lip Seals Configured for Severe High Pressure & Chemical Washdown Environments
- ◆ 316 Stainless Steel Housings & Shafts
- ◆ HACCP Compatible
- ◆ BISSC Certified
- ◆ Packaged with LEESON Washguard® All-Stainless Motors
- ◆ Rebuild for Life Longevity Program
- ◆ Patent Pending



Hub³™ Stainless Steel Bevel Gear Drives

Features:

- ◆ Five Models: M3, 165, 175, 65 and 66
- ◆ Designed to be Compliant with NSF/ANSI/3-A 14159-1—2002
- ◆ Surface Finish Machined to a R_a of 70 μ in
- ◆ Factory Filled with USDA H1 Lubricant for Application Service Life of the Drive
- ◆ Sealed Non-Vented Housing
- ◆ High Pressure Dual Lip Seals Configured for Severe High Pressure & Chemical Washdown Environments
- ◆ 316 Series Stainless Steel Housings & Shafts
- ◆ HACCP Compatible
- ◆ BISSC Certified
- ◆ Rebuild for Life Longevity Program
- ◆ Patent Pending



Introducing: Hub³™ Stainless Steel Helical-Bevel Gear Drives

See page O-19 for details.

CleanLine Ultra Plus™ Stainless Steel Mounted Bearings

Features:

- ◆ 304 Stainless Steel Housing
- ◆ 440 Stainless Steel Rings and Balls
- ◆ 302 Stainless Steel Flingers and Retainers
- ◆ Factory Filled with USDA H1 Lubricant
- ◆ Machine Polished to NSF/3-A or Industry Approved Standards
- ◆ Bore Sizes Up to 1.9375
- ◆ HACCP Compatible



CleanLine Plus™ Intermediate Solutions



CleanLine Plus™ AD Series Bevel Gear Drives

Features:

- ◆ Three Models: AD3, AD4, AD5
- ◆ 303 Stainless Steel Shafts
- ◆ Aluminum Housings with Platinum Plus™ Finish
- ◆ Factory Filled with USDA H1 Lubricant for Application Service Life of the Drive
- ◆ High Pressure Seals with V-Rings
- ◆ 1/1 and 2/1 Spiral Bevel Gears
- ◆ BISSC Certification Optional



CleanLine Plus™ Modified & Custom Drives

Features:

- ◆ Designs Tailored to Your Specifications
- ◆ Meets Unique Application Needs
- ◆ Special Fabrications
- ◆ Corrosion Resistant Treatments such as Powder or Stainless Steel Paint



CleanLine Plus™ Thermoplastic Composite Mounted Bearings

Features:

- ◆ Ultradur® Glass Reinforced PBT Thermoplastic Housings
- ◆ 440 Stainless Steel Rings and Balls
- ◆ 302 Stainless Steel Flingers and Retainers
- ◆ Factory Filled with USDA H1 Lubricant
- ◆ Smooth Surface for Easy Cleaning
- ◆ Bore Sizes Up to 1.5"

CleanLine™ Basic Solutions

CleanLine™ High Efficiency Gear Drives

Features:

- ◆ FDA Approved White Acrylic Paint
- ◆ 303 Stainless Steel Output Shafts
- ◆ Stainless Steel Hardware and Nameplate
- ◆ BISSC Certification Optional
- ◆ Available in All Standard Models of Helical Bevel, Helical Worm, Helical Parallel & Helical InLine
- ◆ USDA/FDA Approved Stainless Steel Paint Optional



CleanLine™ Worm & Bevel Gear Drives

Features:

- ◆ FDA Approved White Acrylic Paint
- ◆ 303 Stainless Steel Output Shafts
- ◆ Stainless Steel Hardware and Nameplate
- ◆ BISSC Certification Optional
- ◆ Available in All Standard Models
- ◆ USDA/FDA Approved Stainless Steel Paint Optional
- ◆ Most Popular Models Available in 5 Days or Less



How To Select & Order Hub Cube Models

Worm Gear Drives:

1. When ordering a worm gear reducer, it is necessary to select reducer size (series), gear ratio, model and assembly style. If accessories are required, they must be ordered separately and in addition to the reducer.
2. Selection Information: Refer to pages B-8, B-9 and B-10.
3. Mechanical Ratings: Refer to page O-9 for mechanical rating parameters.
4. Thermal Ratings: Series SS180, SS210, and SS260 Hub Cube Worm Gear Reducers are not thermally limited. The application service factors associated with mechanical selection and rating, pages B-8, B-9 and O-9, address thermal requirements for the above listed units. In some applications a Thermal Rating may apply to SS320 Worm Gear Drives. If the mechanical service factor selected for a SS320 is 1.50 or less consult the factory with your application information for further assistance.
5. Lubrication and Installation: All Hub Cube Worm Gear Reducers are configured and supplied with the correct quantity of lubricating oil from the factory for all horizontal and vertical shaft mounting positions, EXCEPT for THREE UNAPPROVED mounting positions shown in

figure SSW1. For applications requiring mounting in any of these unapproved mounting positions, CONSULT HUB CITY. For additional Worm Gear Hub Cube Lubrication and Installation information, refer to CleanLine Hub³™ pages of Section R.

Bevel Gear Drives:

1. Refer to page D-3 for selection of a Hub Cube Bevel Gear Drive.
2. Lubrication and Installation: A Mounting position for a Hub Cube Bevel Gear Drive must be specified at the time of placing the order. (See figure SSB1 for mounting positions.) All Hub Cube Bevel Gear Drives are configured and supplied with the correct quantity of lubricating oil for the specified mounting position. For additional Bevel Hub³™ Lubrication and Installation information, refer to CleanLine Hub³™ pages of Section R.

Helical Bevel Gear Drives:

1. Refer to section K for selection, page O-19 for ratings.

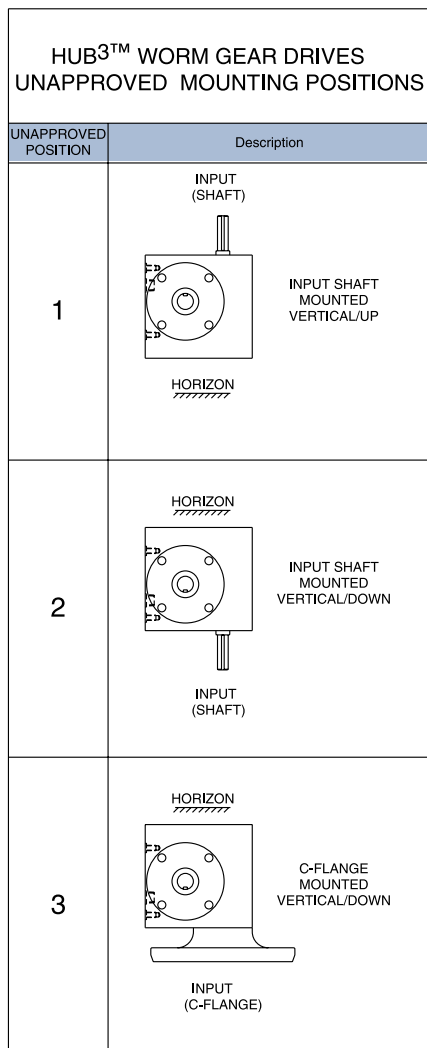

Figure SSW1

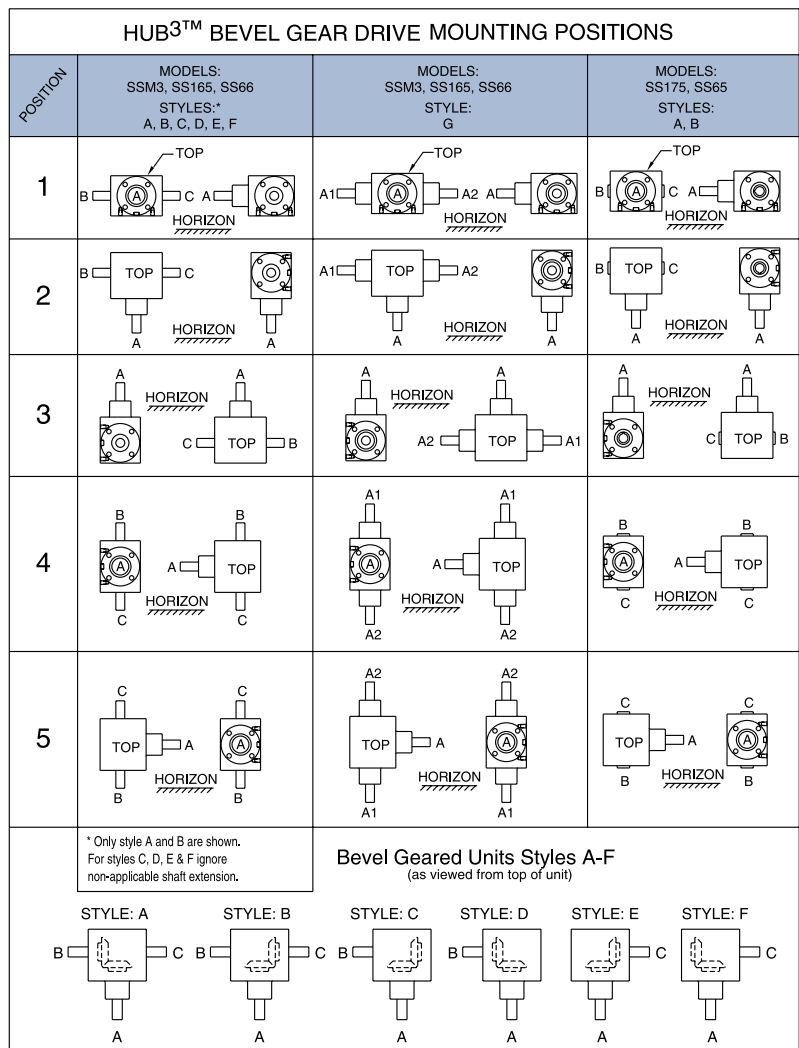

Figure SSB1

CleanLine UltraPlus™ & Pharmaceutical

SERIES SS180				SS210		SS260		SS320	
R A T I O	Output R.P.M.	SERVICE FACTOR		SERVICE FACTOR		SERVICE FACTOR		SERVICE FACTOR	
		1.00		1.00		1.00		1.00	
		Input H.P.	Output Torque	Input H.P.	Output Torque	Input H.P.	Output Torque	Input H.P.	Output Torque
1750 RPM INPUT SPEED (HIGH SPEED SHAFT)									
5	350.0	2.17	358	3.01	492	4.47	723	11.1	1820
7.5	233.0	1.72	415	—	—	—	—	—	—
10	175.0	1.51	472	2.01	621	3.91	1260	7.51	2323
15	116.6	1.12	500	1.52	663	2.51	1110	5.43	2390
20	87.5	.922	536	1.31	748	2.34	1380	4.42	2490
25	70.0	.754	518	1.16	804	2.16	1600	3.76	2550
30	58.3	.675	518	.930	684	1.52	1140	3.29	2450
40	43.8	.547	536	.787	748	1.36	1380	2.67	2490
50	35.0	.439	489	.673	765	1.21	1530	2.23	2440
60	29.2	.365	448	.537	640	.838	986	1.89	2330
1150 RPM INPUT SPEED (HIGH SPEED SHAFT)									
5	230.0	1.73	436	2.40	601	3.67	915	9.02	2270
7.5	153.0	1.36	501	—	—	—	—	—	—
10	115.0	1.13	540	1.64	776	3.18	1570	5.89	2820
15	76.6	.880	598	1.23	826	2.06	1410	4.40	3020
20	57.5	.750	659	1.05	918	1.89	1710	3.60	3170
25	46.0	.583	608	.874	929	1.55	1760	3.06	3250
30	38.3	.530	618	.752	858	1.23	1450	2.63	3120
40	28.8	.431	633	.624	912	1.09	1710	2.14	3170
50	23.0	.345	580	.533	928	.920	1780	1.76	3090
60	19.1	.268	533	.412	761	.670	1250	1.51	2970
850 RPM INPUT SPEED (HIGH SPEED SHAFT)									
5	170.0	1.42	482	2.02	685	3.16	1070	7.87	2700
7.5	113.0	1.12	551	—	—	—	—	—	—
10	85.0	.929	593	1.36	871	2.64	1760	5.08	3310
15	56.6	.750	678	1.03	929	1.74	1610	3.79	3540
20	42.5	.587	688	.873	1019	1.58	1920	3.07	3680
25	34.0	.501	692	.659	929	1.17	1760	2.57	3710
30	28.3	.440	676	.624	954	1.04	1660	2.24	3630
40	21.2	.351	687	.525	1010	.911	1920	1.81	3680
50	17.0	.285	631	.410	934	.695	1780	1.51	3590
60	14.1	.236	573	.312	761	.564	1430	1.13	3030
690 RPM INPUT SPEED (HIGH SPEED SHAFT)									
5	138.0	1.22	508	1.77	735	2.81	1170	7.03	2970
7.5	92.0	1.00	606	—	—	—	—	—	—
10	69.0	.792	620	1.19	928	2.30	1870	4.51	3620
15	46.0	.620	685	.898	987	1.52	1730	3.36	3860
20	34.5	.503	717	.754	1077	1.38	2040	2.72	4010
25	27.6	.411	690	.537	929	1.01	1867	2.09	3710
30	23.0	.379	706	.550	1014	.921	1780	2.01	4010
40	17.2	.306	715	.455	1070	.798	2030	1.60	4000
50	13.8	.251	668	.334	934	.569	1780	1.28	3740
60	11.5	.196	573	.258	761	.501	1534	.912	3030
100 RPM INPUT SPEED (HIGH SPEED SHAFT)									
5	20.0	.251	642	.364	939	.614	1610	1.56	4210
7.5	13.3	.192	688	—	—	—	—	—	—
10	10.0	.167	749	.253	1150	.473	2320	1.02	4980
15	6.6	.135	805	.202	1220	.346	2230	.785	5280
20	5.0	.111	834	.156	1190	.304	2510	.583	4840
25	4.0	.084	703	.104	929	.174	1760	.383	3710
30	3.3	.093	829	.139	1250	.234	2290	.517	5420
40	2.5	.077	830	.109	1200	.189	2380	.391	4880
50	2.0	.061	708	.075	934	.120	1780	.265	3740
60	1.6	.048	573	.060	761	.110	1500	.197	3030



**Hub³™ Worm
Gear Drives
Mechanical
Rating (1.0 SF)
& Continuous
Duty Thermal
Rating***

* A thermal rating may apply to some SS320 applications. See reference #4 on page O-8 for further information

OVERHUNG LOAD - LOW SPEED SHAFT — MODELS 181 AND 184 400 LBS. AT CENTER POINT OF SHAFT EXTENSION. MODELS 182, AND 185 NOT APPLICABLE.
MODELS 211 AND 214 550 LBS. AT CENTER POINT OF SHAFT EXTENSION. MODELS 212, AND 215 NOT APPLICABLE.
MODELS 261 AND 264 850 LBS. AT CENTER POINT OF SHAFT EXTENSION. MODELS 262, AND 265 NOT APPLICABLE.
MODELS 321 AND 324 1,100 LBS. AT CENTER POINT OF SHAFT EXTENSION. MODELS 322, AND 325 NOT APPLICABLE.

*OHL and Thrust values shown are independent functions and cannot be applied simultaneously. Refer applications with combined OHL and Thrust to Hub City Customer Service Department.

CleanLine UltraPlus™ & Pharmaceutical



Hub³™ Worm Gear Drives Models SS181, SS211, SS261 & SS321

Features:

- ◆ 316 Stainless Steel Housings & Output Shafts
- ◆ Plated Input Shafts
- ◆ Sealed Non-Vented Housing
- ◆ High Pressure Dual Lip Seals Configured for Severe High Pressure & Chemical Washdown Environments
- ◆ Factory Filled with USDA H1 Lubricant
- ◆ Universal Mounting Capability

NOTE: CLEANLINE PHARMACEUTICAL FEATURES POLISHED EXTERIOR SURFACES. TO ORDER SPECIFY SSP: EXAMPLE SSP181

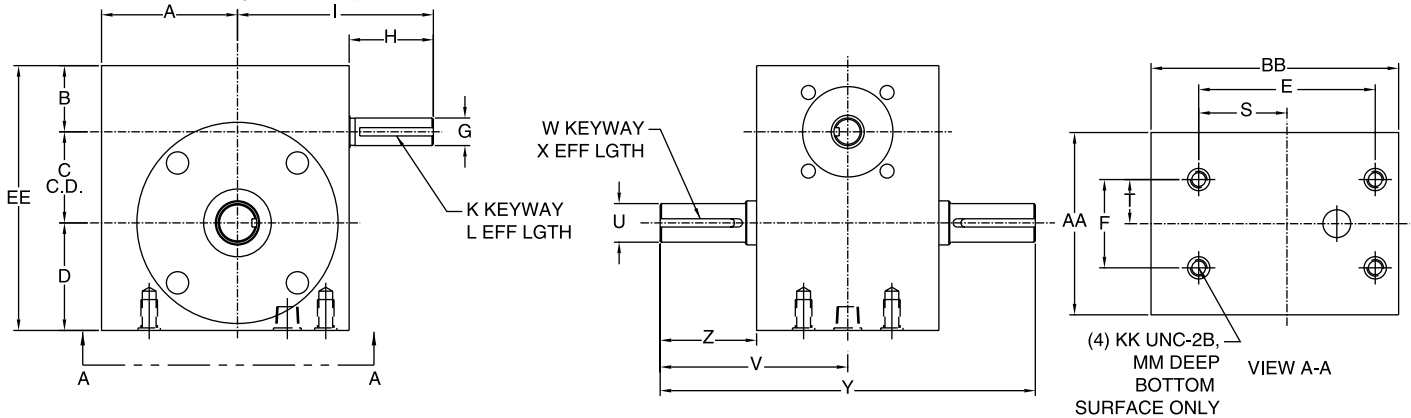
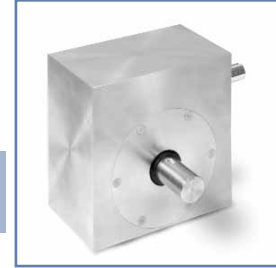

MODEL	A	B	C	D	E	F	G	H	I	K	L
SS181	2.65	1.374	1.751	1.875	3.125	1.625	.500/.499	1.83	4.00	1/8 X 1/16	1.40
SS211	3.08	1.499	2.064	2.437	4.000	2.000	.625/.624	1.91	4.44	3/16 X 3/32	1.38
SS261	3.46	1.874	2.626	2.938	4.875	2.688	.625/.624	2.73	5.63	3/16 X 3/32	2.20
SS321	4.20	2.124	3.251	3.250	6.250	2.750	.875/.874	2.56	6.75	3/16 X 3/32	2.00

MODEL	S	T	U	V	W	X	Y	Z	AA	BB
SS181	1.56	.81	.750/.749	3.50	3/16 X 3/32	1.30	7.00	1.75	3.50	4.82
SS211	2.00	1.00	.875/.874	4.25	3/16 X 3/32	1.59	8.50	2.19	4.13	5.61
SS261	2.44	1.34	1.250/1.249	4.50	1/4 X 1/8	1.78	9.00	2.23	4.54	6.36
SS321	3.13	1.38	1.375/1.374	5.44	5/16 X 5/32	2.05	10.88	2.74	5.40	8.39

MODEL	EE	KK	MM	Weight (lbs)
SS181	5.000	1/4 NC	.50	16
SS211	6.000	3/8 NC	.70	25
SS261	7.438	3/8 NC	.70	37
SS321	8.625	1/2 NC	.90	75

FOR LUBRICATION AND INSTALLATION INSTRUCTIONS - REFER TO SECTION R

Standard Styles Available

DIMENSIONS SHOWN ARE FOR REFERENCE ONLY. CERTIFIED PRINTS ARE AVAILABLE UPON REQUEST.

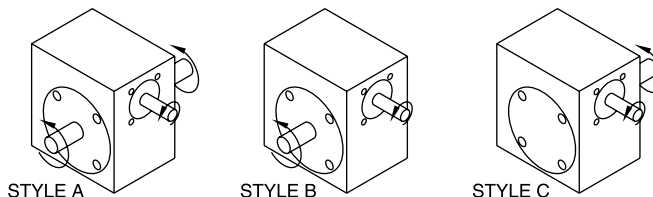

CONSULT FACTORY FOR VERTICAL INPUT SHAFT LUBRICATION RECOMMENDATIONS
INPUT SHAFT CAN BE ROTATED IN EITHER DIRECTION



CleanLine UltraPlus™ & Pharmaceutical

Hub³™ Worm Gear Drives Models SS182, SS212, SS262 & SS322

Features:

- ◆ 316 Stainless Steel Housings & Output Sleeves
- ◆ Plated Input Shafts
- ◆ Sealed Non-Vented Housing
- ◆ High Pressure Dual Lip Seals Configured for Severe High Pressure & Chemical Washdown Environments
- ◆ Factory Filled with USDA H1 Lubricant
- ◆ Universal Mounting Capability

NOTE: CLEANLINE PHARMACEUTICAL FEATURES POLISHED EXTERIOR SURFACES. TO ORDER SPECIFY SSP: EXAMPLE SSP182

SHAFT MOUNTED UNITS REQUIRE TORQUE ARM. TORQUE ARM KITS ARE AVAILABLE, SEE PAGE O-22

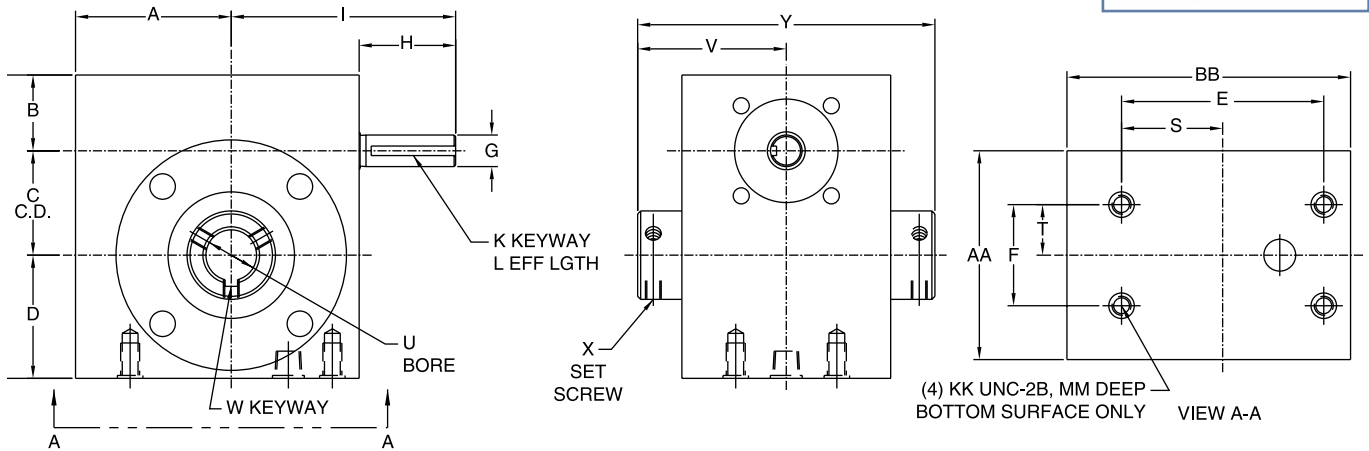
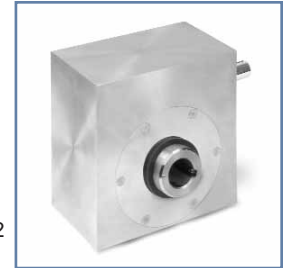

MODEL	A	B	C	D	E	F	G	H	I	K	L	S	T	V	Y
SS182	2.65	1.374	1.751	1.875	3.125	1.625	.500/.499	1.83	4.00	1/8 X 1/16	1.40	1.56	.81	2.40	4.81
SS212	3.08	1.499	2.064	2.437	4.000	2.000	.625/.624	1.91	4.44	3/16 X 3/32	1.38	2.00	1.00	2.94	5.88
SS262	3.46	1.874	2.626	2.938	4.875	2.688	.625/.624	2.73	5.63	3/16 X 3/32	2.20	2.44	1.34	3.12	6.25
SS322	4.20	2.124	3.251	3.250	6.250	2.750	.875/.874	2.56	6.75	3/16 X 3/32	2.00	3.13	1.38	3.78	7.56

STOCK BORES				
MODEL	U	W	X	Key Furnished
SS182	.9375	1/4 X 1/8	1/4 UNC	1/4 Sq.
	1.000 (MAX)	1/4 X 1/8	1/4 UNC	1/4 Sq.
SS212	1.000	1/4 X 1/8	5/16 UNC	1/4 Sq.
	1.1875	1/4 X 1/8	5/16 UNC	1/4 Sq.
SS262	1.250 (MAX)	1/4 X 1/8	5/16 UNC	1/4 Sq.
	1.000	1/4 X 1/8	5/16 UNC	1/4 Sq.
SS262	1.1875	1/4 X 1/8	5/16 UNC	1/4 Sq.
	1.250	1/4 X 1/8	5/16 UNC	1/4 Sq.
SS322	1.4375 (MAX)	3/8 X 1/8	1/4 UNC OVER KW 5/16 UNC NON KW	3/8 X 5/16
	1.4375	3/8 X 3/16	3/8 UNC	3/8 Sq.
SS322	1.9375	1/2 X 1/4	3/8 UNC	1/2 Sq.
	2.188 (MAX)	1/2 X 1/8	3/8 UNC	1/2 Sq.

MODEL	AA	BB	EE	KK	MM	Weight (lbs)
SS182	3.50	4.82	5.000	1/4 NC	.50	16
SS212	4.13	5.61	6.000	3/8 NC	.70	25
SS262	4.54	6.36	7.438	3/8 NC	.70	37
SS322	5.40	8.39	8.625	1/2 NC	.90	75

BORE TOLERANCE: NOMINAL +.002

Standard Styles Available

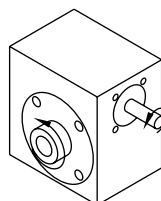

FOR LUBRICATION AND INSTALLATION INSTRUCTIONS - REFER TO SECTION R

DIMENSIONS SHOWN ARE FOR REFERENCE ONLY. CERTIFIED PRINTS ARE AVAILABLE UPON REQUEST.

CONSULT FACTORY FOR VERTICAL INPUT SHAFT LUBRICATION RECOMMENDATIONS
INPUT SHAFT CAN BE ROTATED IN EITHER DIRECTION

CleanLine UltraPlus™ & Pharmaceutical



Hub³™ Motorized Worm Gear Drives Models SS184, SS214, SS264 & SS324

Features:

- ◆ 316 Stainless Steel Housings & Shafts
- ◆ LEESON Washguard All-Stainless Motors
- ◆ Integrated Rear Conduit Box 1/4 thru 1 hp
- ◆ Sealed Non-Vented Housing
- ◆ High Pressure Dual Lip Seals Configured for Severe High Pressure & Chemical Washdown Environments
- ◆ Factory Filled with USDA H1 Lubricant
- ◆ Universal Mounting Capability

FOR LUBRICATION AND INSTALLATION INSTRUCTIONS - REFER TO SECTION R

NOTE: CLEANLINE PHARMACEUTICAL FEATURES POLISHED EXTERIOR SURFACES. TO ORDER SPECIFY SSP: EXAMPLE SSP184

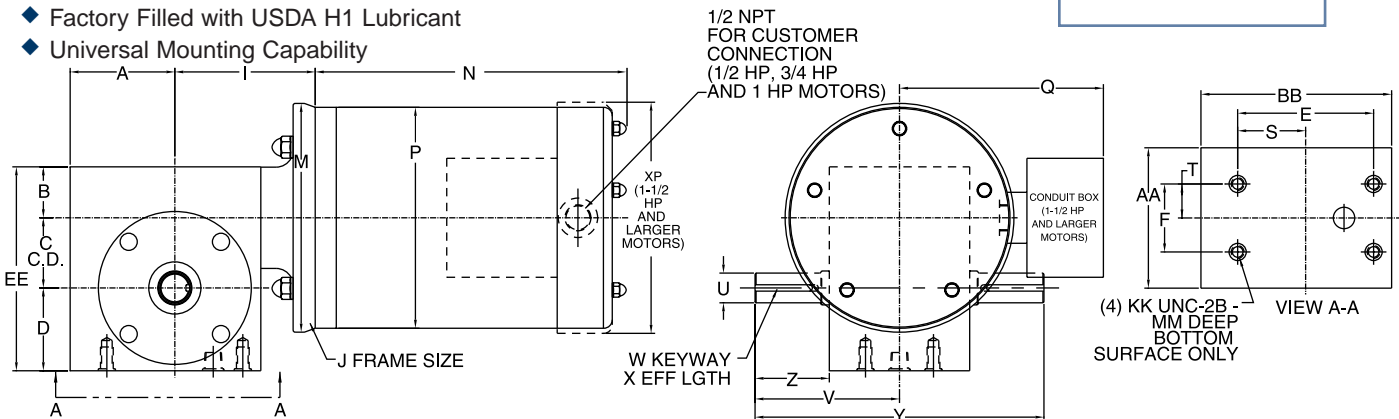

MODEL	A	B	C	D	E	F	I	J	M	MOTOR HP	FRAME	STYLE	N	P	Q	XP	MOTOR WT
SS184	2.65	1.374	1.751	1.875	3.125	1.625	3.75	56C	6.73	1/4 HP	56C	TENV	9.15	6.50	NA	NA	30
SS214	3.08	1.499	2.064	2.437	4.000	2.000	4.13	56C	6.73	1/3 HP	56C	TENV	9.15	6.50	NA	NA	30
								143TC		1/2 HP	56C	TENV	10.15	6.50	NA	NA	32
SS264	3.46	1.874	2.626	2.938	4.875	2.688	4.50	56C	6.73	3/4 HP	56C	TENV	10.65	6.50	NA	NA	39
								143TC		1 HP	56C	TENV	11.65	6.50	NA	NA	40
								182TC		1-1/2 HP	143TC	TEFC	11.57	6.60	6.19	7.16	46
SS324	4.20	2.124	3.251	3.250	6.250	2.750	5.50	56C	6.73	2 HP	143TC	TEFC	12.07	6.60	6.19	7.16	47
								143TC		3 HP	182TC	TEFC	11.99	8.53	7.19	9.22	67
								182TC		5 HP	182TC	TEFC	12.99	8.53	7.19	9.22	79
								182TC									

MOTORS ARE 1750 RPM - 230/460 VOLT - 3 PHASE

MODEL	S	T	U	V	W	X	Y	Z	AA	BB	EE	KK	MM	WEIGHT* (lbs)
SS184	1.56	.81	.750/.749	3.50	3/16 X 3/32	1.30	7.00	1.75	3.50	4.82	5.000	1/4 NC	.50	21
SS214	2.00	1.00	.875/.874	4.25	3/16 X 3/32	1.59	8.50	2.19	4.13	5.61	6.000	3/8 NC	.70	30
SS264	2.44	1.34	1.250/1.249	4.50	1/4 X 1/8	1.78	9.00	2.23	4.54	6.36	7.438	3/8 NC	.70	42
SS324	3.13	1.38	1.375/1.374	5.44	5/16 X 5/32	2.05	10.88	2.74	5.40	8.39	8.625	1/2 NC	.90	80

*Weight of gear box only -does not include motor.

Standard Styles Available

DIMENSIONS SHOWN ARE FOR REFERENCE ONLY. CERTIFIED PRINTS ARE AVAILABLE UPON REQUEST.

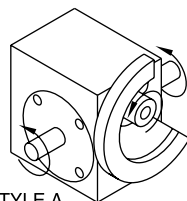

STYLE A

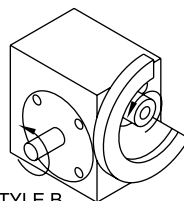

STYLE B

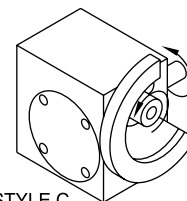

STYLE C

CONSULT FACTORY FOR VERTICAL INPUT SHAFT LUBRICATION RECOMMENDATIONS
INPUT SHAFT CAN BE ROTATED IN EITHER DIRECTION



CleanLine UltraPlus™ & Pharmaceutical

Hub³™ Motorized Worm Gear Drives Models SS185, SS215, SS265 & SS325

Features:

- ◆ 316 Stainless Steel Housings & Output Sleeves
- ◆ LEESON Washguard All-Stainless Motors
- ◆ Integrated Rear Conduit Box 1/4 thru 1 hp
- ◆ Sealed Non-Vented Housing
- ◆ High Pressure Dual Lip Seals Configured for Severe High Pressure & Chemical Washdown Environments
- ◆ Factory Filled with USDA H1 Lubricant
- ◆ Universal Mounting Capability

FOR LUBRICATION AND INSTALLATION INSTRUCTIONS - REFER TO SECTION R

NOTE: CLEANLINE PHARMACEUTICAL FEATURES POLISHED EXTERIOR SURFACES. TO ORDER SPECIFY SSP: EXAMPLE SSP185

SHAFT MOUNTED UNITS REQUIRE TORQUE ARM. TORQUE ARM KITS ARE AVAILABLE, SEE PAGE O-22

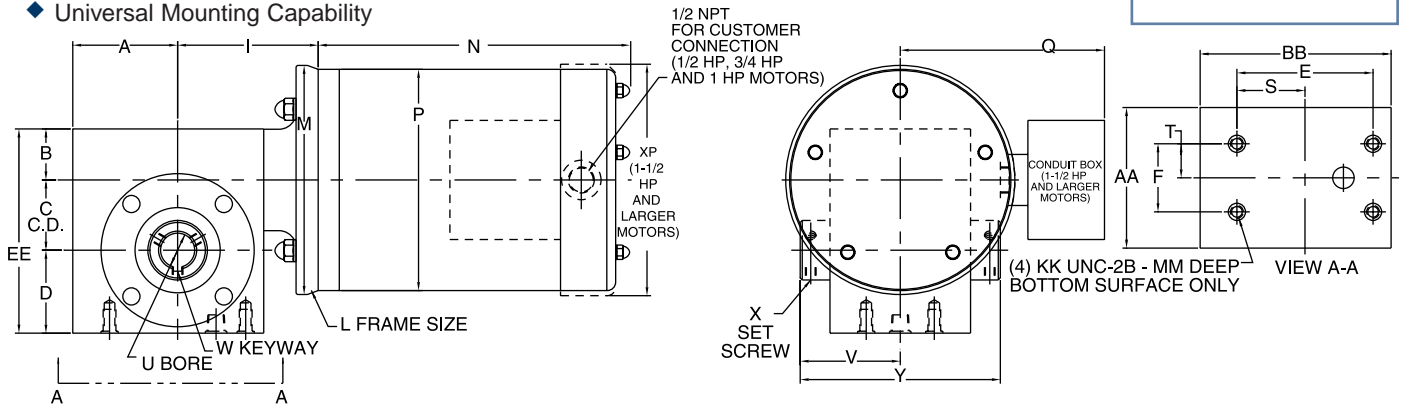

MODEL	A	B	C	D	E	F	I	J	M
SS185	2.65	1.374	1.751	1.875	3.125	1.625	3.75	56C	6.73
SS215	3.08	1.499	2.064	2.437	4.000	2.000	4.13	56C	6.73
								143TC	
SS265	3.46	1.874	2.626	2.938	4.875	2.688	4.50	56C	6.73
								143TC	
								182TC	9.00
SS325	4.20	2.124	3.251	3.250	6.250	2.750	5.50	56C	6.73
								143TC	
								182TC	9.00

MOTOR HP	FRAME	STYLE	N	P	Q	XP	MOTOR WT
1/4 HP	56C	TENV	9.15	6.50	NA	NA	30
1/3 HP	56C	TENV	9.15	6.50	NA	NA	30
1/2 HP	56C	TENV	10.15	6.50	NA	NA	32
3/4 HP	56C	TENV	10.65	6.50	NA	NA	39
1 HP	56C	TENV	11.65	6.50	NA	NA	40
1-1/2 HP	143TC	TEFC	11.57	6.60	6.19	7.16	46
2 HP	143TC	TEFC	12.07	6.60	6.19	7.16	47
3 HP	182TC	TEFC	11.99	8.53	7.19	9.22	67
5 HP	182TC	TEFC	12.99	8.53	7.19	9.22	79

MOTORS ARE 1750 RPM - 230/460 VOLT - 3 PHASE

MODEL	S	T	V	Y	AA	BB	EE	KK	MM	WGT* (lbs)
SS185	1.56	.81	2.40	4.81	3.50	4.82	5.000	1/4 NC	.50	21
SS215	2.00	1.00	2.94	5.88	4.13	5.61	6.000	3/8 NC	.70	30
SS265	2.44	1.34	3.12	6.25	4.54	6.36	7.438	3/8 NC	.70	42
SS325	3.13	2.75	3.78	7.56	5.40	8.39	8.625	1/2 NC	.90	80

*Weight of gear box only -does not include motor.

STOCK BORES				
MODEL	U	W	X	Key Furnished
SS185	.9375	1/4 X 1/8	1/4 UNC	1/4 Sq.
	1.000 (MAX)	1/4 X 1/8	1/4 UNC	1/4 Sq.
SS215	1.000	1/4 X 1/8	5/16 UNC	1/4 Sq.
	1.1875	1/4 X 1/8	5/16 UNC	1/4 Sq.
	1.250 (MAX)	1/4 X 1/8	5/16 UNC	1/4 Sq.
SS265	1.000	1/4 X 1/8	5/16 UNC	1/4 Sq.
	1.1875	1/4 X 1/8	5/16 UNC	1/4 Sq.
	1.250	1/4 X 1/8	5/16 UNC	1/4 Sq.
	1.4375 (MAX)	3/8 X 1/8	1/4 UNC OVER KW 5/16 UNC NON KW	3/8 X 5/16
SS325	1.4375	3/8 X 3/16	3/8 UNC	3/8 Sq.
	1.9375	1/2 X 1/4	3/8 UNC	1/2 Sq.
	2.188 (MAX)	1/2 X 1/8	3/8 UNC	1/2 Sq.

BORE TOLERANCE: NOMINAL +.002

DIMENSIONS SHOWN ARE FOR REFERENCE ONLY. CERTIFIED PRINTS ARE AVAILABLE UPON REQUEST.

Standard Styles Available

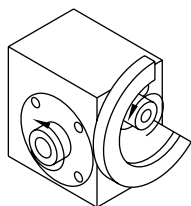

CONSULT FACTORY FOR VERTICAL INPUT SHAFT LUBRICATION RECOMMENDATIONS
INPUT SHAFT CAN BE ROTATED IN EITHER DIRECTION

CleanLine UltraPlus™ & Pharmaceutical



Hub³™ Bevel Gear Drives Model SSM3

Features

- ◆ 316 Series Stainless Steel Housings & Shafts
- ◆ All Exterior Surfaces Machined
- ◆ Precision Ball Bearings to Accommodate Higher Operating Speeds.
- ◆ Choice of Five (5) Gear Ratios.
- ◆ Sealed — Non-Vented Housing
- ◆ Factory Configured for Universal Mounting Assures Maximum Design Flexibility
- ◆ High Pressure Dual Lip Seals Configured for Severe High Pressure & Chemical Washdown Environments
- ◆ Factory Filled with USDA H1 Lubricant



NOTE: CLEANLINE PHARMACEUTICAL FEATURES POLISHED EXTERIOR SURFACES. TO ORDER SPECIFY SSPM3

Rating Table

INPUT RPM†		REDUCTION RATIOS				
		1:1	SPIRAL 1:1Δ	1.5:1	2:1	SPIRAL 2:1Δ
3000	INPUT HORSEPOWER		3.59	2.60	1.75	1.77
	OUTPUT TORQUE IN. LBS.		75.50	82.00	73.00	74.20
	‡INPUT O.H.L.		25.00	72.00	83.00	30.00
	‡OUTPUT O.H.L.		70.00	200.00	245.00	100.00
2400	INPUT HORSEPOWER	3.00	2.95	2.10	1.40	1.45
	OUTPUT TORQUE IN. LBS.	79.00	77.40	83.00	74.00	76.10
	‡INPUT O.H.L.	67.00	45.00	85.00	90.00	50.00
	‡OUTPUT O.H.L.	155.00	105.00	220.00	270.00	135.00
1750	INPUT HORSEPOWER	2.25	2.19	1.57	1.04	1.07
	OUTPUT TORQUE IN. LBS.	81.00	78.70	84.00	75.00	77.20
	‡INPUT O.H.L.	88.00	60.00	98.00	102.00	70.00
	‡OUTPUT O.H.L.	177.00	150.00	245.00	300.00	180.00
1150	INPUT HORSEPOWER	1.50	1.47	1.03	.70	.72
	OUTPUT TORQUE IN. LBS.	83.00	80.30	85.00	77.00	78.60
	‡INPUT O.H.L.	110.00	90.00	118.00	121.00	95.00
	‡OUTPUT O.H.L.	205.00	175.00	290.00	350.00	210.00
850	INPUT HORSEPOWER	1.13	1.10	.80	.53	.54
	OUTPUT TORQUE IN. LBS.	84.00	81.30	88.00	78.00	79.40
	‡INPUT O.H.L.	131.00	100.00	137.00	142.00	105.00
	‡OUTPUT O.H.L.	240.00	210.00	320.00	382.00	240.00
690	INPUT HORSEPOWER	.93	.90	.65	.43	.44
	OUTPUT TORQUE IN. LBS.	85.00	81.90	89.00	80.00	80.00
	‡INPUT O.H.L.	137.00	110.00	144.00	148.00	112.00
	‡OUTPUT O.H.L.	267.00	230.00	350.00	400.00	270.00
400	INPUT HORSEPOWER	.55	.53	.39	.26	.26
	OUTPUT TORQUE IN. LBS.	87.00	83.30	92.00	82.00	81.20
	‡INPUT O.H.L.	169.00	125.00	175.00	180.00	138.00
	‡OUTPUT O.H.L.	330.00	300.00	400.00	400.00	330.00
300	INPUT HORSEPOWER	.42	.40	.30	.20	.19
	OUTPUT TORQUE IN. LBS.	88.00	84.70	95.00	83.00	82.40
	‡INPUT O.H.L.	189.00	150.00	190.00	190.00	152.00
	‡OUTPUT O.H.L.	378.00	400.00	400.00	400.00	400.00
100	INPUT HORSEPOWER	.14	.14	.12	.08	.07
	OUTPUT TORQUE IN. LBS.	90.00	85.80	113.00	100.00	83.20
	‡INPUT O.H.L.	190.00	160.00	190.00	190.00	175.00
	‡OUTPUT O.H.L.	400.00	400.00	400.00	400.00	400.00

†For Higher Input Speeds Consult Factory.

‡Overhung Load In Pounds At Center Of Shaft Extensions.
ΔMfg. To Order - Consult Factory for Price and Delivery.



CleanLine UltraPlus™ & Pharmaceutical

Hub³™ Bevel Gear Drives Models SS165 & SS175

Features

- ◆ 316 Series Stainless Steel Housings & Shafts
- ◆ All Exterior Surface Machined
- ◆ Tapered Roller Bearings for Endurance and Strength
- ◆ Choice of Seven (7) Gear Ratios
- ◆ Sealed — Non-Vented Housing
- ◆ Factory Configured for Universal Mounting Assures Maximum Design Flexibility
- ◆ High Pressure Dual Lip Seals Configured for Severe High Pressure & Chemical Washdown Environments
- ◆ Factory Filled with USDA H1 Food Grade Lubricant



NOTE: CLEANLINE PHARMACEUTICAL FEATURES POLISHED EXTERIOR SURFACES. TO ORDER SPECIFY SSP165 OR SSP175

Rating Table

INPUT RPM†		REDUCTION RATIOS						
		1:1*	SPIRAL 1:1	1.5:1*	SPIRAL 1.5:1	2:1*	SPIRAL 2:1	SPIRAL 3:1
3000	INPUT HORSEPOWER		26.87		28.00		15.10	8.70
	OUTPUT TORQUE IN. LBS.		564.00		883.00		634.00	548.00
	‡INPUT O.H.L.		25.00		25.00		55.00	225.00
	‡OUTPUT O.H.L.		160.00		200.00		550.00	625.00
2400	INPUT HORSEPOWER		21.80		22.70	9.00	12.25	7.00
	OUTPUT TORQUE IN. LBS.		570.00		895.00	341.00	629.00	554.00
	‡INPUT O.H.L.		54.00		50.00	330.00	85.00	275.00
	‡OUTPUT O.H.L.		215.00		225.00	410.00	665.00	700.00
1750	INPUT HORSEPOWER		16.00	9.20	16.90	6.25	9.00	5.20
	OUTPUT TORQUE IN. LBS.		580.00	500.00	911.00	442.00	636.00	562.00
	‡INPUT O.H.L.		114.00	366.00	75.00	372.00	115.00	350.00
	‡OUTPUT O.H.L.		265.00	320.00	275.00	455.00	745.00	775.00
1150	INPUT HORSEPOWER	17.00	11.00	6.20	11.30	4.25	6.05	3.50
	OUTPUT TORQUE IN. LBS.	930.00	600.00	510.00	930.00	465.00	650.00	571.00
	‡INPUT O.H.L.	79.00	182.00	426.00	125.00	434.00	135.00	475.00
	‡OUTPUT O.H.L.	260.00	310.00	380.00	375.00	525.00	800.00	800.00
850	INPUT HORSEPOWER	13.00	8.30	4.70	8.50	3.25	4.50	2.60
	OUTPUT TORQUE IN. LBS.	960.00	615.00	520.00	941.00	481.00	657.00	576.00
	‡INPUT O.H.L.	121.00	211.00	473.00	250.00	481.00	155.00	575.00
	‡OUTPUT O.H.L.	305.00	355.00	425.00	450.00	555.00	800.00	800.00
690	INPUT HORSEPOWER	10.60	6.80	3.90	6.90	2.70	3.70	2.10
	OUTPUT TORQUE IN. LBS.	970.00	620.00	530.00	950.00	494.00	669.00	578.00
	‡INPUT O.H.L.	156.00	243.00	508.00	325.00	517.00	185.00	600.00
	‡OUTPUT O.H.L.	345.00	395.00	470.00	500.00	575.00	800.00	800.00
400	INPUT HORSEPOWER	6.30	4.10	2.30	4.10	1.60	2.15	1.24
	OUTPUT TORQUE IN. LBS.	1000.00	645.00	550.00	964.00	504.00	671.00	586.00
	‡INPUT O.H.L.	374.00	319.00	600.00	375.00	600.00	390.00	600.00
	‡OUTPUT O.H.L.	425.00	475.00	610.00	650.00	780.00	800.00	800.00
300	INPUT HORSEPOWER	5.00	3.10	1.80	3.10	1.25	1.65	.94
	OUTPUT TORQUE IN. LBS.	1010.00	650.00	560.00	974.00	525.00	678.00	592.00
	‡INPUT O.H.L.	450.00	384.00	600.00	475.00	600.00	505.00	600.00
	‡OUTPUT O.H.L.	500.00	550.00	655.00	750.00	800.00	800.00	800.00
100	INPUT HORSEPOWER	1.65	1.10	.65	1.05	.50	.55	.32
	OUTPUT TORQUE IN. LBS.	1040.00	693.00	615.00	993.00	630.00	679.00	605.00
	‡INPUT O.H.L.	600.00	600.00	600.00	600.00	600.00	600.00	600.00
	‡OUTPUT O.H.L.	775.00	800.00	800.00	800.00	800.00	800.00	800.00

†For Higher Input Speeds Consult Factory.
* Not Available in Model 175

‡Overhung Load In Pounds At Center Of Shaft Extensions.

CleanLine UltraPlus™ & Pharmaceutical



Hub³™ Bevel Gear Drives Models SS66 & SS65

Features

- ◆ 316 Series Stainless Steel Housings & Shafts
- ◆ All Exterior Surface Machined
- ◆ Tapered Roller Bearings for Endurance and Strength
- ◆ Choice of Seven (7) Gear Ratios
- ◆ Sealed — Non-Vented Housing
- ◆ Factory Configured for Universal Mounting Assures Maximum Design Flexibility
- ◆ High Pressure Dual Lip Seals Configured for Severe High Pressure & Chemical Washdown Environments
- ◆ Factory Filled with USDA H1 Food Grade Lubricant

NOTE: CLEANLINE PHARMACEUTICAL FEATURES POLISHED EXTERIOR SURFACES. TO ORDER SPECIFY SSP66 OR SSP65

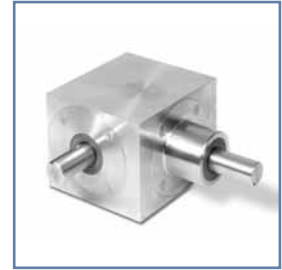

Rating Table

INPUT RPM†		REDUCTION RATIOS						
		1:1*	SPIRAL 1:1	1.5:1*	SPIRAL 1.53:1	2:1*	SPIRAL 2:1	SPIRAL 3:1
3000	INPUT HORSEPOWER				56.00		25.50	15.40
	OUTPUT TORQUE IN. LBS.				1765.00		1072.00	951.00
	‡INPUT O.H.L.				38.00		100.00	35.00
	‡OUTPUT O.H.L.				80.00		725.00	100.00
2400	INPUT HORSEPOWER		59.00		46.00		20.67	12.50
	OUTPUT TORQUE IN. LBS.		1550.00		1810.00		1085.00	961.00
	‡INPUT O.H.L.		30.00		59.00		125.00	45.00
	‡OUTPUT O.H.L.		65.00		100.00		800.00	225.00
1750	INPUT HORSEPOWER		46.00	15.00	35.00	7.30	15.40	9.20
	OUTPUT TORQUE IN. LBS.		1650.00	810.00	1887.00	525.00	1112.00	975.00
	‡INPUT O.H.L.		62.00	351.00	97.00	459.00	225.00	85.00
	‡OUTPUT O.H.L.		100.00	300.00	140.00	330.00	900.00	350.00
1150	INPUT HORSEPOWER	24.20	30.50	10.60	23.00	5.40	10.30	6.15
	OUTPUT TORQUE IN. LBS.	1320.00	1670.00	870.00	1930.00	591.00	1125.70	989.00
	‡INPUT O.H.L.	126.00	109.00	446.00	133.00	521.00	400.00	100.00
	‡OUTPUT O.H.L.	190.00	160.00	340.00	190.00	380.00	1075.00	500.00
850	INPUT HORSEPOWER	19.00	24.00	8.20	18.00	4.50	7.68	4.60
	OUTPUT TORQUE IN. LBS.	1410.00	1790.00	910.00	2000.00	667.00	1139.00	998.00
	‡INPUT O.H.L.	158.00	143.00	524.00	161.00	567.00	525.00	195.00
	‡OUTPUT O.H.L.	230.00	210.00	400.00	230.00	440.00	1080.00	750.00
690	INPUT HORSEPOWER	16.30	20.00	7.10	15.00	3.90	6.28	3.75
	OUTPUT TORQUE IN. LBS.	1480.00	1830.00	970.00	2050.00	712.00	1147.00	1009.00
	‡INPUT O.H.L.	213.00	178.00	558.00	217.00	603.00	600.00	215.00
	‡OUTPUT O.H.L.	265.00	250.00	445.00	270.00	465.00	1080.00	800.00
300	INPUT HORSEPOWER	8.14	10.00	3.50	7.00	1.80	2.80	1.65
	OUTPUT TORQUE IN. LBS.	1700.00	2100.00	1100.00	2205.00	756.00	1177.00	1031.00
	‡INPUT O.H.L.	418.00	312.00	744.00	421.00	806.00	900.00	550.00
	‡OUTPUT O.H.L.	425.00	420.00	645.00	425.00	715.00	1080.00	1080.00
100	INPUT HORSEPOWER	2.86	3.70	1.40	3.00	.70	.95	.55
	OUTPUT TORQUE IN. LBS.	1800.00	2330.00	1320.00	2835.00	882.00	1198.00	1056.00
	‡INPUT O.H.L.	625.00	493.00	900.00	611.00	900.00	900.00	800.00
	‡OUTPUT O.H.L.	695.00	685.00	965.00	685.00	1080.00	1080.00	1080.00
WR ² (Lb. In. ²) REFERRED TO HIGH SPEED SHAFT	STYLE							
	A, B	6.29	5.42	3.10	4.04	1.87	2.17	1.24
	C, D, E, F	6.08	5.21	3.00	3.96	1.82	2.12	1.22
	G	8.76	7.45	4.43	6.27	2.59	3.19	1.68
	GG	9.21	7.90	4.46	5.47	2.81	3.08	1.97
WR ² (Lb. In. ²) REFERRED TO LOW SPEED SHAFT	A, B	6.29	5.42	6.97	9.42	7.50	8.67	11.17
	C, D, E, F	6.08	5.21	6.76	9.22	7.29	8.46	10.96
	G	8.76	7.45	9.96	14.62	10.35	12.77	15.16
	GG	9.21	7.90	10.03	12.74	11.22	12.33	17.70

†For Higher Input Speeds Consult Factory.

* Not Available in Model 65

‡Overhung Load In lbs. At Center of Shaft Extensions.



CleanLine UltraPlus™ & Pharmaceutical

Hub³™ Bevel Gear Drives Models SSM3, SS165 & SS66

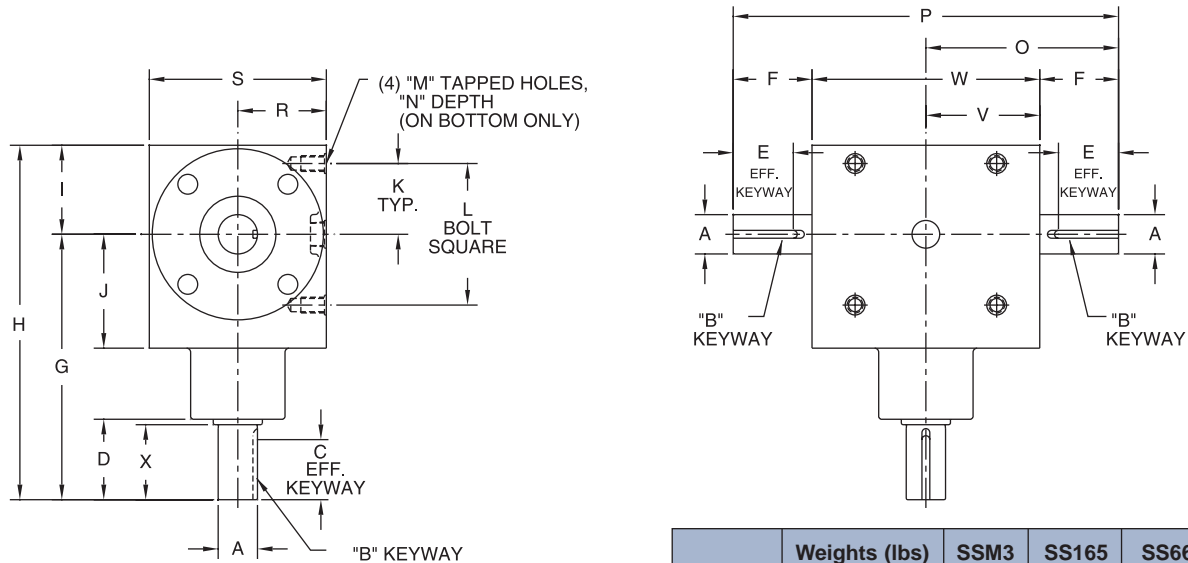

	Weights (lbs)	SSM3	SS165	SS66
Styles	A,B,C,D,E,F	13	31	54
Styles	G	16	39	65

Model	A	B	C	D	E	F	G	H	I	J
SSM3	0.625 0.624	3/16 X 3/32 KW	1.00*	1.53	1.00	1.35	4.57	6.20	1.63	1.89
SS165	1.000 0.999	1/4 X 1/8 KW	1.44**	2.03	1.53	2.07	7.16	9.72	2.56	3.03
SS66	1.250 1.249	1/4 X 1/8 KW	1.91	2.56	1.91	2.51	8.44	11.27	2.83	3.62

Model	K	L	M	N	O	P	R	S	V	W	X
SSM3	1.125	2.250	5/16-18UNC-2B	0.44	3.24	6.47	1.594	3.188	1.89	3.78	N/A
SS165	2.125	4.250	3/8-16UNC-2B	0.69	5.10	10.19	2.313	4.625	3.03	6.06	1.89
SS66	2.250	4.500	1/2-13UNC-2B	0.81	6.13	12.25	2.814	5.628	3.62	7.24	N/A

* - 1.16 Effective Keyway on SSM3, 2/1 Straight Bevel Ratio
 ** - 1.53 Effective Keyway on SS165, 3/1 Spiral Bevel Ratio

NOTE: STYLE G:
 1. DIMENSIONS FOR SHAFTS A, A1 AND A2 ARE IDENTICAL FOR ALL RATIOS.
 2. CENTERLINE TO END OF SHAFT DIMENSIONS WILL VARY. REQUEST CERTIFIED DIMENSIONAL PRINTS.

"A" shaft extension on SSM3 2/1 straight bevel, SS165 3/1 spiral bevel and SS66 3/1 spiral bevel ratios are made from 8620 steel treated for corrosion resistance.

Standard Styles Available

(Viewed from Top of Gear Drives - Mounting Holes on Bottom Surface Only)

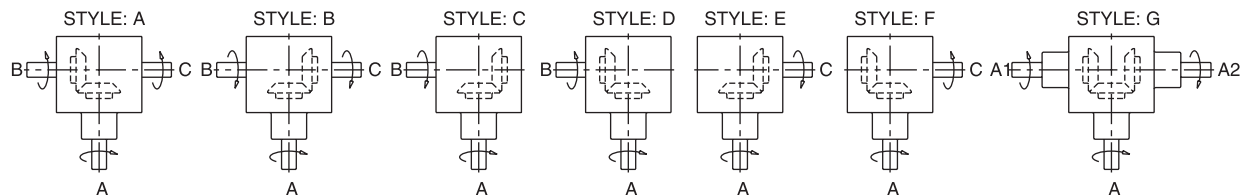

CONSULT FACTORY FOR VERTICAL SHAFT LUBRICATION RECOMMENDATIONS
 INPUT SHAFT CAN BE ROTATED IN EITHER DIRECTION

DIMENSIONS SHOWN ARE FOR REFERENCE ONLY.
 CERTIFIED PRINTS ARE AVAILABLE UPON REQUEST.

CleanLine UltraPlus™ & Pharmaceutical



Hub³™ Bevel Gear Drives Models SS175 & SS65

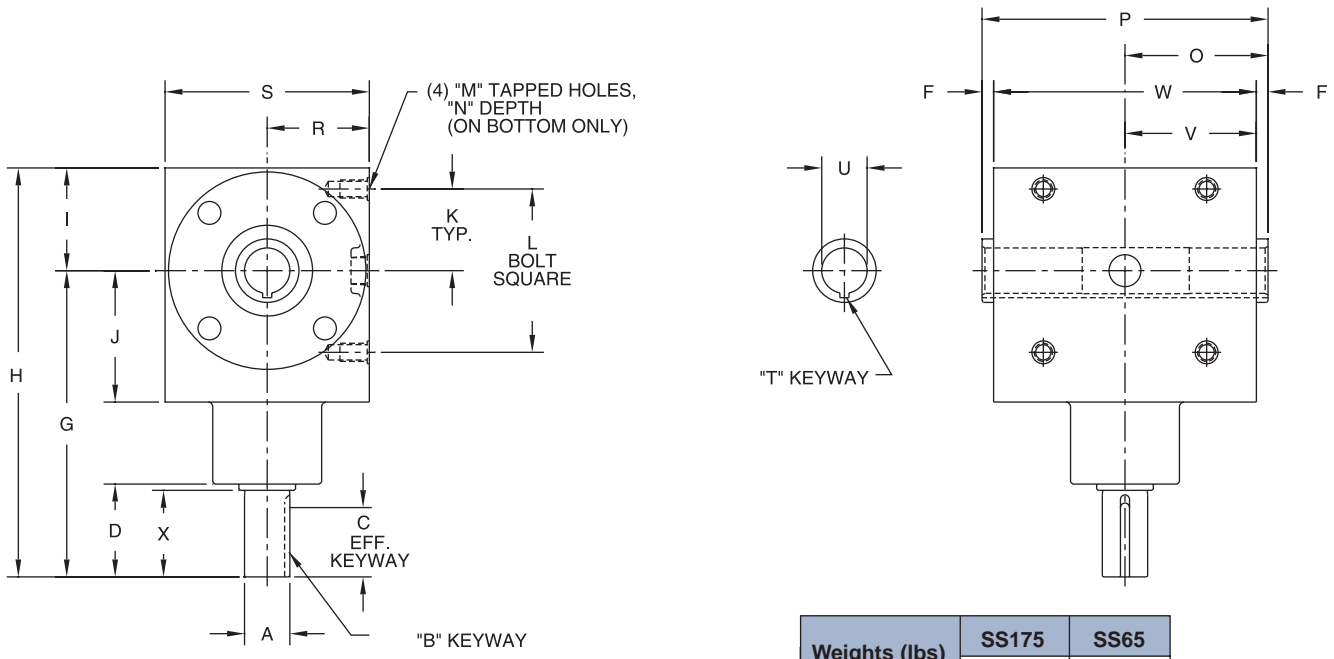

Weights (lbs)	SS175	SS65
	33	60

Model	A	B	C	D	F	G	H	I	J	K	L
SS175	1.000 0.999	1/4 X 1/8 KW	1.44*	2.03	0.17	7.16	9.72	2.56	3.03	2.125	4.250
SS65	1.250 1.249	1/4 X 1/8 KW	1.91	2.56	0.32	8.44	11.27	2.83	3.62	2.250	4.500

Model	M	N	O	P	R	S	T	U	V	W	X
SS175	3/8-16UNC-2B	0.69	3.20	6.40	2.313	4.625	1/4 X 1/8 KW	1.0000 1.0025	3.03	6.06	1.89
SS65	1/2-13UNC-2B	0.81	3.94	7.88	2.814	5.628	1/4 X 1/8 KW	1.2500 1.2525	3.62	7.24	N/A

* - 1.53 Effective Keyway on SS175, 3/1 Spiral Bevel Ratio

"A" shaft extension on SS175 3/1 spiral bevel and SS65 3/1 spiral bevel ratios are made from 8620 steel treated for corrosion resistance.

Standard Styles Available

(Viewed from Top of Gear Drives - Mounting Holes on Bottom Surface Only)

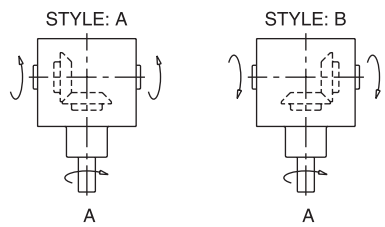

CONSULT FACTORY FOR VERTICAL SHAFT LUBRICATION RECOMMENDATIONS
INPUT SHAFT CAN BE ROTATED IN EITHER DIRECTION

DIMENSIONS SHOWN ARE FOR REFERENCE ONLY.
CERTIFIED PRINTS ARE AVAILABLE UPON REQUEST.



CleanLine UltraPlus™ & Pharmaceutical

Hub³™ Helical-Bevel Gear Drives Models SSHB2043 & SSHB2063

Features

- ◆ Ratios from 6:1 to 140:1
- ◆ Power Ratings from 3/4 to 12 hp
- ◆ 316 Stainless Steel Housing and Shafts
- ◆ Surface Finish Machined to R_a of 70µin
- ◆ Patent Pending



NOTE: CLEANLINE PHARMACEUTICAL FEATURES POLISHED EXTERIOR SURFACES. TO ORDER SPECIFY SSHBP2043 OR SSHBP2063

Rating Table

SSH2043						
Ratio	Output Speed	Input H.P.	Output Torque	Output OHL	Input OHL	Output Thrust
6.53	268	10	2210	650	140	1730
7.31	239	9.0	2230	675	140	1730
9.24	189	7.5	2350	700	140	1730
12.07	145	7.6	3100	800	140	1950
13.51	130	6.9	3150	770	140	1950
17.08	102	5.8	3350	830	140	1950
21.94	80	4.8	3540	930	140	1950
25.10	70	4.2	3540	1050	140	1950
30.37	58	3.4	3540	1150	140	1950
38.38	46	2.7	3540	1250	140	1950
49.31	35	2.1	3540	1250	140	1950
56.41	31	1.9	3540	1250	140	1950
73.76	24	1.4	3540	1250	140	1950
91.94	19	1.1	3540	1250	140	1950
110.88	16	0.9	3540	1250	140	1950
127.45	14	0.8	3540	1250	140	1950
SSH2063						
6.22	281	12	2530	2050	200	2850
7.46	235	11	2880	2050	200	2850
9.44	185	10	3250	2050	200	2850
11.25	156	11	4060	2050	200	2850
13.48	130	12	5320	2050	200	2850
17.06	103	9.9	5720	2050	200	2850
19.80	88	9.2	6200	2050	200	2850
25.89	68	7.4	6500	2050	200	2850
30.51	57	6.8	7000	2050	200	2850
38.61	45	5.5	7150	2050	200	2850
44.81	39	4.8	7250	2050	200	2850
58.58	30	3.7	7260	2050	200	2850
69.99	25	3.1	7260	2050	200	2850
74.56	23	2.9	7260	2050	200	2850
85.21	21	2.5	7260	2050	200	2850
91.47	19	2.3	7260	2050	200	2850
106.51	16	2.0	7260	2050	200	2850
115.64	15	1.9	7260	2050	200	2850
126.17	14	1.7	7260	2050	200	2850
138.46	13	1.5	7260	2050	200	2850

All torque values listed in inch-pounds, all overhung load and thrust load values listed in pounds. The point of application of OHL is considered to be applied at the midpoint of shaft extension. Input OHL applies only to shaft input models. OHL and thrust ratings cannot be applied simultaneously. Consult the factory for applications with combined OHL and thrust load. At speeds above 1750 RPM, units may become thermally limited. For extended operation, limit HP to 1750 RPM rating.

CleanLine UltraPlus™ & Pharmaceutical



Hub³™ Helical-Bevel Gear Drives Models SSHB2043 & SSHB2063

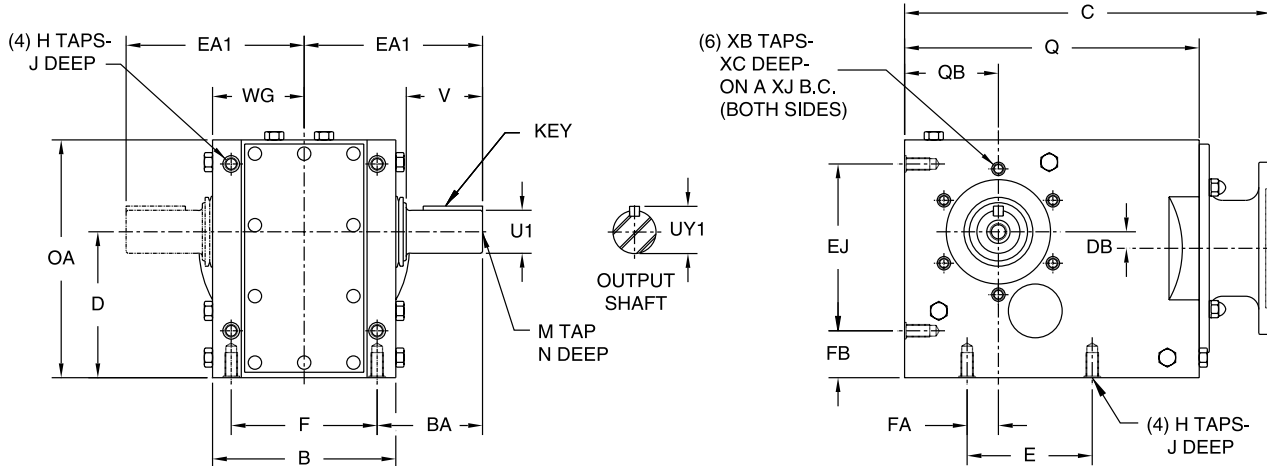

Gearcase

Dimensions are $\frac{\text{inch}}{\text{mm}}$

Model	B	D	DB	E	EJ	F	FA
SSHB2043E*	5.71	4.41 ⁺⁰ _{-.02}	0.47	5.12	5.12	4.72	1.38
	145	112 ⁺⁰ _{-.5}	12.0	130	130	120	35
SSHB2063E*	6.92	5.51 ⁺⁰ _{-.02}	0.62	4.72	6.30	5.51	1.18
	176	140 ⁺⁰ _{-.5}	15.8	120	160	140	30

Gearcase

Model	FB	H	J	OA	Q	QB	WG
SSHB2043E*	1.46	-	0.63	7.48	9.82	2.80	2.85
	37	M10 x 1.5	16	190	249	71	72.5
SSHB2063E*	1.77	-	0.95	8.98	11.13	3.54	3.46
	45	M12 x 1.75	24	228	283	90	87.9

Gearcase

Model	XB	XC	XJ
SSHB2043E*	-	0.63	3.875
	M8 x 1.25	16.0	98.43
SSHB2063E*	-	0.66	4.750
	M10 x 1.5	16.8	120.65

Output Shaft

Model	BA	EA1	U1	UY1	V	KEY	M	N
SSHB2043E*	2.95	5.31	1.250 ⁺⁰ _{-.001}	1.36	2.04	1/4 x 1/4 x 1-1/2	1/2 - 13UNC	1.20
	75	135	-	-	-	-	-	-
SSHB2063E*	3.98	6.73	1.625 ⁺⁰ _{-.001}	1.78	2.88	3/8 x 3/8 x 2-1/4	5/8 - 11UNC	1.38
	101	171	-	-	-	-	-	-

Output Sleeve

Model	AM	EA2	EH	U2	UF	UY2	KEY
SSHB2043ES	0.48	3.34	6.67	1.375 ^{+0.0025} _{-.0}	1.97	1.52	(2) 5/16 x 5/16 x 1-13/16
	12	84.7	-	-	-	-	-
SSHB2063ES	0.38	3.84	7.68	1.500 ^{+0.0025} _{-.0}	2.20	1.67	(2) 3/8 x 3/8 x 2-1/4
	10	97.5	-	-	-	-	-

Motor Compatibility - NEMA

Model	NEMA		
	56C	143TC	182TC
SSHB2043E*	C	12.43	13.80
		316	351
SSHB2063E*	C	13.83	14.85
		351	377

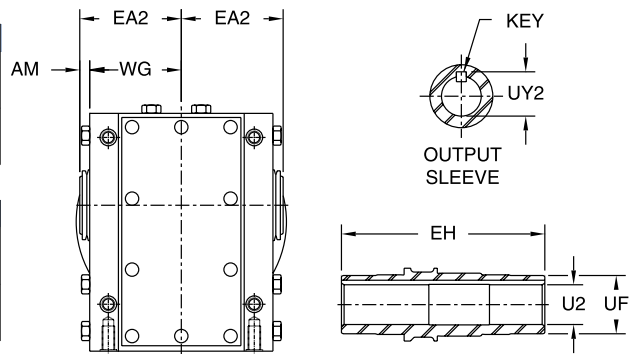

* Output Styles

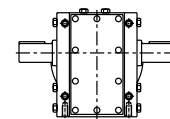

D: Double Ext.

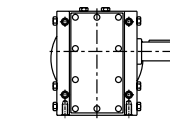

L: Left Ext.

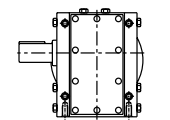

R: Right Ext.

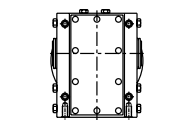

S: Sleeve (Hollow Bore)

Dimensions subject to change without notice

Shaft Input Versions and Stainless Steel Accessories Available, Consult Factory



Hub³™ Accessories

316 Stainless Steel NEMA "C" Flange Adaptor & Universal Base Kits

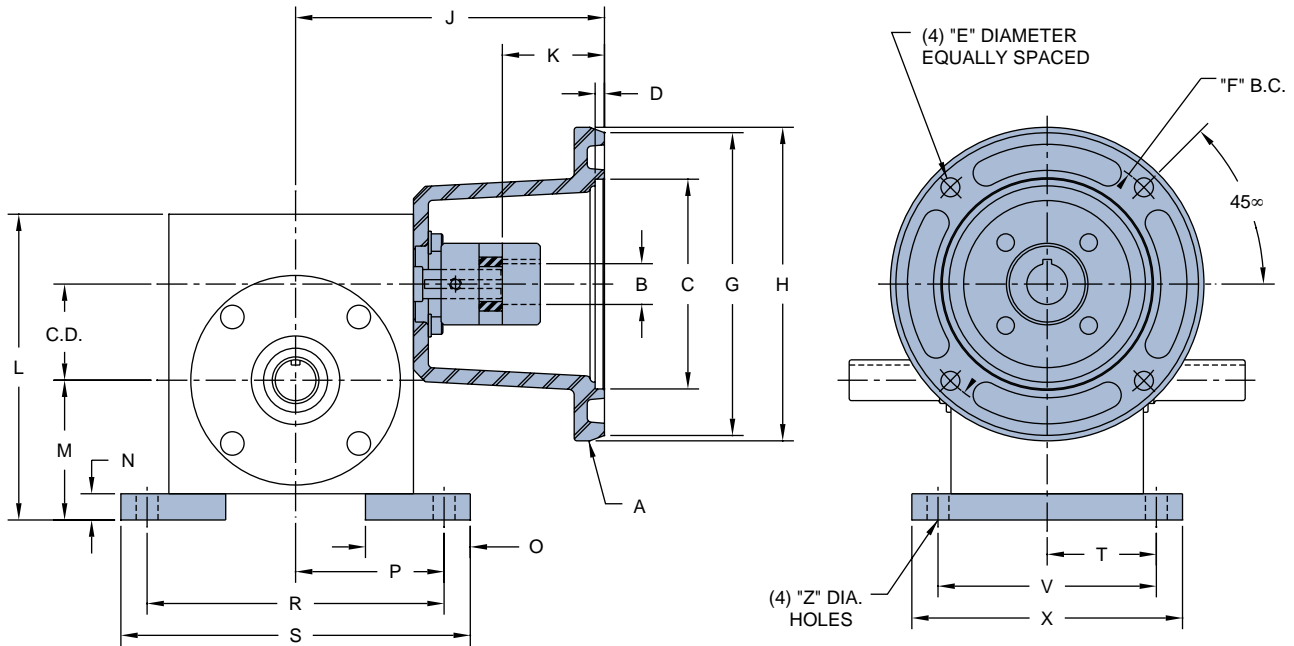

316 STAINLESS STEEL NEMA "C" Flange Adaptor Kits

Series	A-NEMA Flange	Flange Kit No.	Flange Kit Ship Wt.	B	C	D	E	F	G	H	J	K
SS180	56C*	0229-02913*	6.1 lbs.	.625/.626	4.501/4.503	.20	13/32	5.875	6.50	6.73	6.19	2.19
	56C	0229-02914	6.3 lbs.	.625/.626								
SS210	143TC, 145TC, 182C, 184C	0229-02915	6.5 lbs.	.875/.876	4.501/4.503	.20	13/32	5.875	6.50	6.73	6.63	2.19
	56C	0229-02916	8.5 lbs.	.625/.626								
SS260	143TC, 145TC, 182C, 184C	0229-02917	8.3 lbs.	.875/.876	4.501/4.503	.20	13/32	5.875	6.50	6.73	7.82	2.19
	182TC, 184TC, 213C, 215C	0229-02918	17.8 lbs.	1.125/1.126								
SS320	56C	0229-02919	10.3 lbs.	.625/.626	4.501/4.503	.20	13/32	5.875	6.50	6.73	8.94	2.19
	143TC, 145TC, 182C, 184C	0229-02920	10.1 lbs.	.875/.876								
	182TC, 184TC, 213C, 215C	0229-02921	18.5 lbs.	1.125/1.126								

* - Series SS180 Flange adaptor kit must be factory installed.

316 STAINLESS STEEL Universal Base Kits

Series	Base Kit No.	Base Kit Ship Wt.	C.D.	L	M	N	O	P	R	S	T	V	X	Z
SS180	0229-02922	6.5 lbs.	1.751	5.88	2.75	0.88	2.25	2.88	5.75	6.88	2.25	4.50	5.62	13/32 THRU
SS210	0229-02923	4.4 lbs.	2.064	6.56	3.00	0.56	2.25	3.19	6.38	7.50	2.34	4.69	5.81	7/16 UNC TAPPED
SS260	0229-02924	7.8 lbs.	2.626	8.19	3.69	0.75	2.75	4.00	8.00	9.25	2.63	5.25	6.50	17/32 THRU
SS320	0229-02925	14.3 lbs.	3.251	9.75	4.38	1.13	3.00	4.75	9.50	10.75	3.06	6.13	7.38	17/32 THRU

Configured to be Used With or Without Clearance Spacers between Base Kit and Reducer Housing

Hub³™ Accessories



Stainless Steel Torque Arm Bracket Kits & Clearance Spacers

316 STAINLESS STEEL Torque Arm Bracket Kits

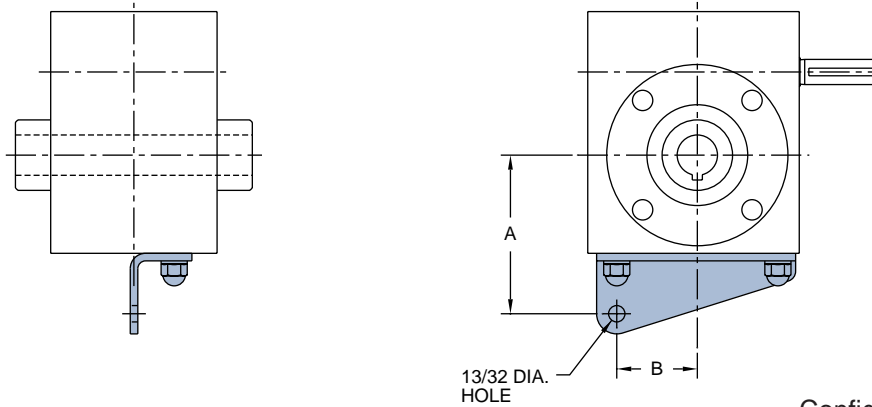

316 STAINLESS Torque Arm Bracket Kits

Series	Base Kit No.	Base Kit Ship Wt.	A	B
SS180	0229-02926	0.6 lbs.	3.25	1.56
SS210	0229-02927	1.4 lbs.	3.94	2.00
SS260	0229-02928	2.0 lbs.	4.94	2.44
SS320	0229-02929	2.5 lbs.	5.50	3.13

Configured to be Used With or Without Clearance Spacers between Base Kit and Reducer Housing

316 STAINLESS STEEL Clearance Spacers

(For Worm Gear and Bevel Gear Drives)

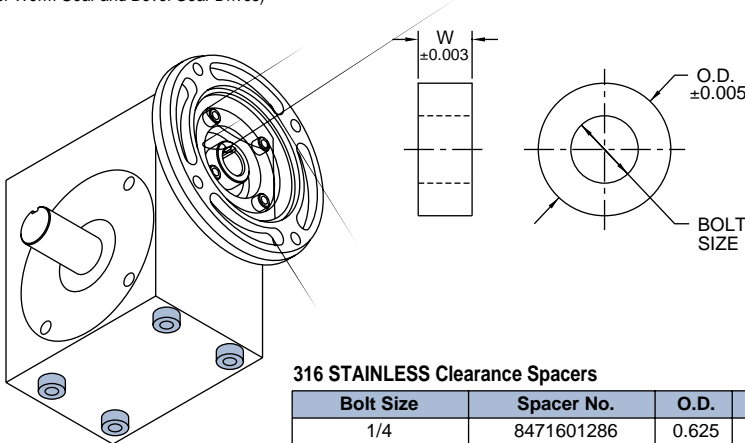

Clearance spacers are an excellent method of adding space between the gearbox and its mounting surface.

Clearance spacers minimize the surface contact area between the gearbox and its mounting surface to reduce potential bacterial growth areas.

Clearance spacers provide space for cleaning brushes to be used during sanitation processes. The spacers allow accessibility when cleaning by high-pressure washing or circulation of flowing chemical solutions, cleaning liquids and water rinses.

316 STAINLESS Clearance Spacers

Bolt Size	Spacer No.	O.D.	W
1/4	8471601286	0.625	0.375
5/16	8471601287	0.688	0.375
3/8	8471601288	0.812	0.375
7/16	8471601289	0.922	0.375
1/2	8471601290	0.969	0.375
5/8	8471601291	1.312	0.375

Order (1) spacer for each mounting hole required. Consult factory for additional sizes available.

Suitable for:
 CleanLine Pharmaceutical
 CleanLine UltraPlus
 CleanLine Plus
 CleanLine Gear Drives



Hub³™ Stainless Shaft Protectors

Shaft Extension and Hollow Sleeve Protector Kits

Worm Gear Drives

Solid Output Shaft

Models: SS_1 & SS_4

(example: Models SS181 & SS184)

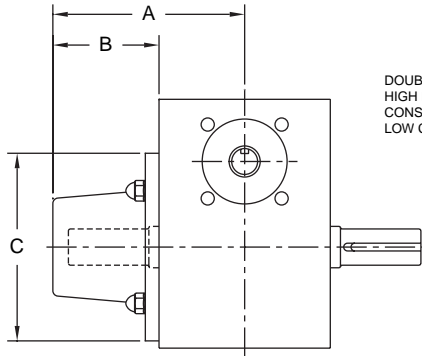

Hollow Output Sleeve

Models: SS_2 & SS_5

(example: Models SS182 & SS185)

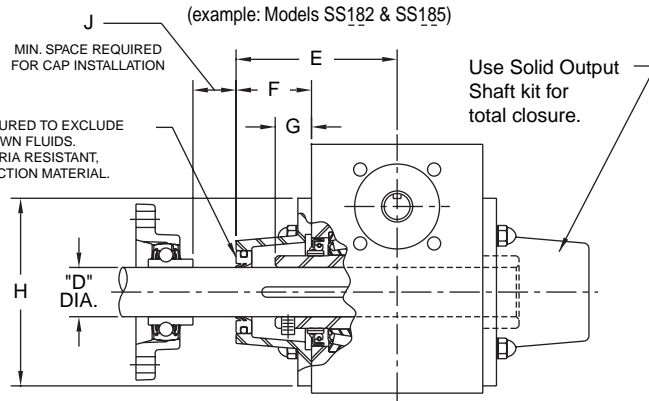

Use Solid Output Shaft kit for total closure.

Solid Output Shaft Kit				
Series	Kit Part Number	A	B	C
SS180	0229-02930	3.91	2.16	3.59
SS210	0229-02931	4.62	2.56	4.53
SS260	0229-02932	5.17	2.90	5.60
SS320	0229-02933	5.83	3.13	6.29

Hollow Output Sleeve Kit							
Series	Kit Part Number	D	E	F	G	H	J
SS180	0229-02934	1.000	3.25	1.50	0.66	3.59	0.81
SS210	0229-02935	1.000	3.88	1.82	0.88	4.53	1.03
	0229-02936	1.188					
	0229-02949	1.250					
SS260	0229-02937	1.000	4.12	1.85	0.86	5.60	1.01
	0229-02938	1.188					
	0229-02948	1.250					
	0229-02939	1.438					
SS320	0229-02940	1.438	5.33	2.63	1.08	6.29	1.23
	0229-02941	1.938					
	0229-02942	2.188					

Bevel Gear Drives

Solid Output Shaft

Models: SSM3, SS165 & SS66

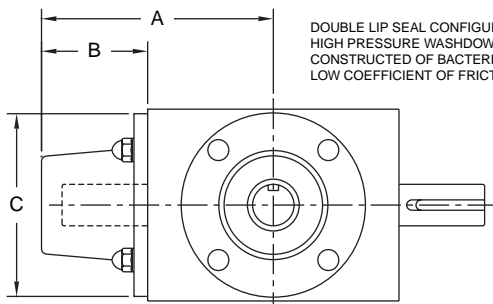

DOUBLE LIP SEAL CONFIGURED TO EXCLUDE HIGH PRESSURE WASHDOWN FLUIDS. CONSTRUCTED OF BACTERIA RESISTANT, LOW COEFFICIENT OF FRICTION MATERIAL.

Hollow Sleeve Output

Models: SS175 & SS65

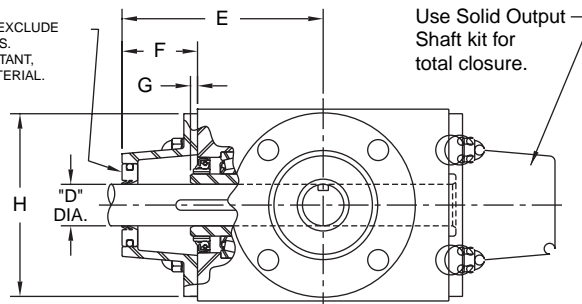

Use Solid Output Shaft kit for total closure.

Solid Output Shaft Kit				
Model	Kit Part Number	A	B	C
SSM3	0229-02943	3.61	1.72	2.85
SS165	0229-02944	5.59	2.56	4.41
SS66	0229-02945	6.52	2.90	5.42

Hollow Output Sleeve Kit						
Model	Kit Part Number	D	E	F	G	H
SS175	0229-02946	1.000	3.85	1.82	0.17	4.41
SS65	0229-02947	1.250	5.47	1.85	0.32	5.42

DIMENSIONS SHOWN ARE FOR REFERENCE ONLY. CERTIFIED PRINTS ARE AVAILABLE UPON REQUEST.

CleanLine UltraPlus™ and Pharmaceutical

Stainless Steel Mounted Bearings - Pillow Block PB251STW

Features:

- ◆ 440 Stainless Steel Rings and Balls
- ◆ 302 Stainless Steel Flingers and Retainers
- ◆ Setscrew Lock - Wide Inner Ring
- ◆ Factory Filled USDA H1 Lubricant Meets FDA Regulation 178.3570 Requirement for Incidental Contact with Food
- ◆ 304 Stainless Steel Setscrews
- ◆ Anti Rotation Pin
- ◆ 304 Stainless Steel Housing
- ◆ No Ribs Undercuts or Protrusions - Easier to Clean
- ◆ Stainless Steel Grease Fittings
- ◆ Grooved for Composite Dust Caps on One Side, See Page O-31

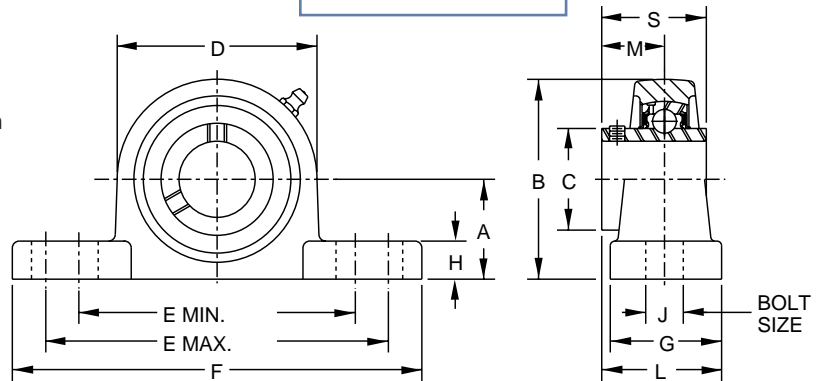

SHAFT SIZE	A	B	C	D	E MIN.	E MAX.	F	G	H	J	L	M	S	Wt. Lbs.
1/2, 5/8	1-5/16	2-9/16	1.142	2-1/2	3-1/2	3-31/32	5	1-1/2	9/16	3/8	1-15/32	0.720	1.220	1.4
3/4	1-5/16	2-9/16	1.142	2-1/2	3-1/2	3-31/32	5	1-1/2	9/16	3/8	1-15/32	0.720	1.220	1.4
7/8, 1	1-7/16	2-3/4	1.339	2-5/8	3-29/32	4-3/8	5-1/2	1-1/2	19/32	3/8	1-17/32	0.780	1.343	1.7
1-1/8, 1-3/16, 1-1/4S	1-11/16	3-9/32	1.587	3-5/32	4-5/8	4-15/16	6-1/2	1-7/8	5/8	1/2	1-53/64	0.874	1.500	2.9
1-1/4, 1-3/8, 1-7/16	1-7/8	3-23/32	1.890	3-21/32	4-27/32	5-5/32	6-9/16	1-7/8	11/16	1/2	1-61/64	1.000	1.689	3.5
1-1/2	1-15/16	3-15/16	2.087	4	5-1/4	5-9/16	7-1/4	2-1/8	23/32	1/2	2-1/4	1.189	1.937	4.4
1-11/16, 1-3/4	2-1/8	4-1/4	2.252	4-1/4	5-9/16	5-15/16	7-1/2	2-1/8	25/32	1/2	2-1/4	1.189	1.937	5.0
1-15/16	2-1/4	4-15/32	2.433	4-15/32	6-1/16	6-15/32	8-1/8	2-3/8	27/32	5/8	2-15/32	1.283	2.031	5.9

Part Numbers are specified by "PB251STW" and Bore Size. Example: PB251STW x 1.
For replacement inserts use B250TW Bearing Inserts, O-28.

For Load Ratings, See page O-28.

Tapped Base Pillow Block TPB250STW

Features: (Same as Above)

FOR LUBRICATION AND INSTALLATION INSTRUCTIONS - REFER TO SECTION R

NOTE: CLEANLINE PHARMACEUTICAL FEATURES POLISHED EXTERIOR SURFACES. TO ORDER SPECIFY SPTW: EXAMPLE PB251SPTWX1

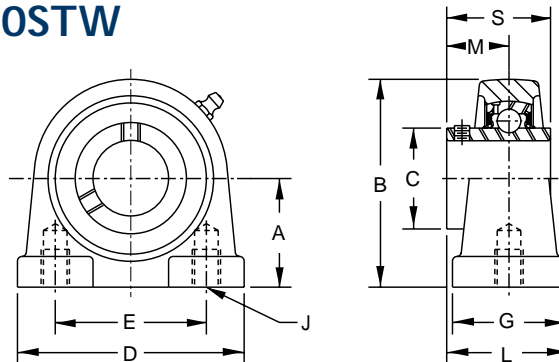

SHAFT SIZE	A	B	C	D	E	G	J - TAPPED HOLES	L	M	S	Wt. Lbs.
1/2, 5/8	1-5/16	2-9/16	1.142	2-7/8	2	1-1/2	3/8-16NC X 1/2	1-15/32	0.720	1.220	0.8
3/4	1-5-16	2-9/16	1.142	2-7/8	2	1-1/2	3/8-16NC X 1/2	1-15/32	0.720	1.220	0.8
7/8, 1	1-7/16	2-13/16	1.339	3	2	1-1/2	3/8-16NC X 1/2	1-17/32	0.780	1.343	0.9
1-1/8, 1-3/16, 1-1/4S	1-11/16	3-7/16	1.587	4	3	1-1/2	7/16-16NC X 5/8	1-5/8	0.874	1.500	1.9
1-1/4, 1-3/8, 1-7/16	1-7/8	3-3/4	1.890	4-1/4	3-1/4	1-7/8	1/2-13NC X 3/4	1-61/64	1.000	1.689	2.0
1-1/2	1-15/16	3-15/16	2.087	4-5/8	3-1/2	1-7/8	1/2-13NC X 3/4	2-9/64	1.189	1.937	2.8
1-11/16, 1-3/4	2-1/8	4-1/4	2.252	5	3-3/4	2	1/2-13NC X 3/4	2-13/64	1.189	1.937	3.3
1-15/16	2-1/4	4-5/8	2.433	5-1/2	4	2	5/8-11NC X 1	2-9/32	1.283	2.031	4.2

Part Numbers are specified by "TPB250STW" and Bore Size. Example: TPB250STW x 3/4.
For replacement inserts use B250TW Bearing Inserts, O-28.

For Load Ratings, See page O-28.

¶ Dimensions shown are for reference only.

Certified prints are available upon request

CleanLine UltraPlus™ and Pharmaceutical

Stainless Steel Mounted Bearings - 4 Bolt Flange Blocks FB250STW

Features:

- ◆ 440 Stainless Steel Rings and Balls
- ◆ 302 Stainless Steel Flingers and Retainers
- ◆ Setscrew Lock - Wide Inner Ring
- ◆ Factory Filled USDA H1 Lubricant Meets FDA Regulation 178.3570 Requirement for Incidental Contact with Food
- ◆ 304 Stainless Steel Setscrews
- ◆ Anti Rotation Pin
- ◆ 304 Stainless Steel Housing
- ◆ No Ribs - Undercuts or Protrusions Easier to Clean
- ◆ Stainless Steel Grease Fittings
- ◆ Grooved for Composite Dust Caps on One Side, See Page O-37

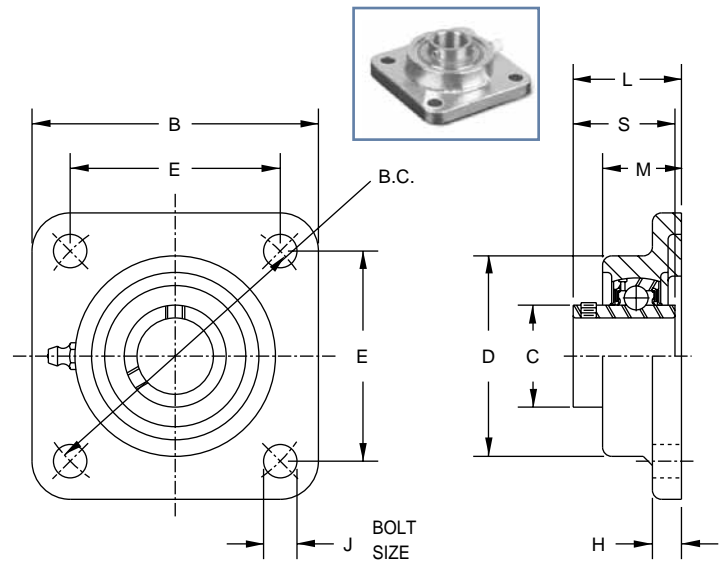

SHAFT SIZE	B	B.C.	C	D	E	H	J	L	M	S	Wt. Lbs.
1/2, 5/8	3-3/8	3-17/32	1.142	2-3/8	2-1/2	7/16	3/8	1-5/16	1-3/64	1.220	1.3
3/4	3-3/8	3-17/32	1.142	2-3/8	2-1/2	7/16	3/8	1-5/16	1-3/64	1.220	1.3
7/8, 1	3-3/4	3-57/64	1.339	2-13/16	2-3/4	1/2	3/8	1-13/32	1-5/64	1.343	1.8
1-1/8, 1-3/16, 1-1/4S	4-1/4	4-19/32	1.587	3-3/16	3-1/4	1/2	3/8	1-37/64	1-7/32	1.500	2.4
1-1/4, 1-3/8, 1-7/16	4-5/8	5-1/8	1.890	3-5/8	3-5/8	19/32	1/2	1-3/4	1-9/32	1.689	3.5
1-1/2	5-1/8	5-21/32	2.087	4-3/32	4	19/32	1/2	2-1/64	1-3/8	1.937	4.2
1-11/16, 1-3/4	5-3/8	5-53/64	2.252	4-1/4	4-1/8	5/8	1/2	2-1/16	1-7/16	1.937	5.3
1-15/16	5-5/8	6-3/16	2.433	4-1/2	4-3/8	5/8	1/2	2-5/32	1-29/64	2.031	5.7

Part Numbers are specified by "FB250STW" and Bore Size. Example: FB250STW x 3/4.
For replacement inserts use B250TW Bearing Inserts, O-28.

For Load Ratings, See page O-28.

2 Bolt Flange Blocks FB260STW

Features: (Same as Above)

FOR LUBRICATION AND INSTALLATION INSTRUCTIONS - REFER TO SECTION R

NOTE: CLEANLINE PHARMACEUTICAL FEATURES POLISHED EXTERIOR SURFACES. TO ORDER SPECIFY SPTW: EXAMPLE FB250SPTW

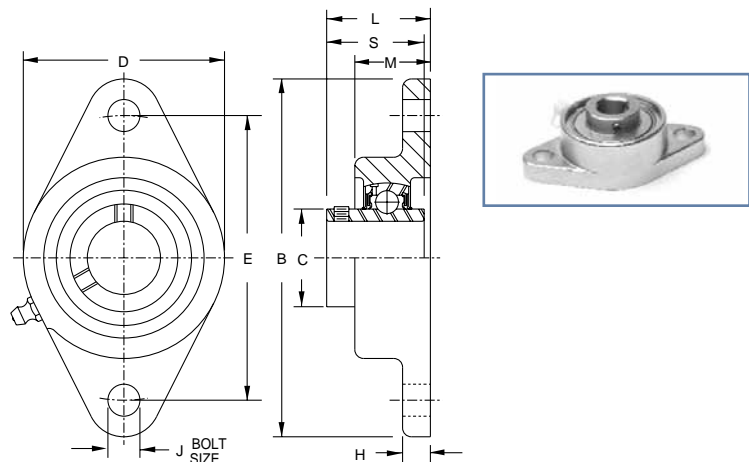

SHAFT SIZE	B	C	D	E	H	J	L	M	S	Wt. Lbs.
1/2S, 5/8S	3-7/8	1.142	2-9/32	3	25/64	3/8	1-5/16	1-3/64	1.220	0.9
1/2, 5/8	4-7/16	1.142	2-3/8	3-17/32	7/16	3/8	1-5/16	1-3/64	1.220	1.1
3/4	4-7/16	1.142	2-3/8	3-17/32	7/16	3/8	1-5/16	1-3/64	1.220	1.0
7/8, 1	5-1/8	1.339	2-11/16	3-57/64	33/64	3/8	1-13/32	1-5/64	1.343	1.4
1-1/8, 1-3/16, 1-1/4S	5-13/16	1.587	3-5/32	4-19/32	33/64	3/8	1-37/64	1-7/32	1.500	1.9
1-1/4, 1-3/8, 1-7/16	6-11/32	1.890	3-17/32	5-1/8	35/64	1/2	1-3/4	1-9/32	1.689	2.6
1-1/2	6-7/8	2.087	3-15/16	5-21/32	35/64	1/2	2-1/64	1-3/8	1.937	3.5
1-11/16, 1-3/4	7-13/32	2.252	4-1/4	5-53/64	19/32	1/2	2-3/64	1-7/16	1.937	4.2
1-15/16	7-3/4	2.433	4-17/32	6-3/16	19/32	1/2	2-5/32	1-15/32	2.031	5.1

Part Numbers are specified by "FB260STW" and Bore Size. Example: FB260STW x 3/4.
For replacement inserts use B250TW Bearing Inserts, O-28.

For Load Ratings, See page O-28.

† Dimensions shown are for reference only.

Certified prints are available upon request

CALL: (605) 225-0360



FAX: (605) 225-0567

O-25

CleanLine Plus™ Thermoplastic

Composite Mounted Bearings - Pillow Block PB251CTW

Features:

- ◆ 440 Stainless Steel Rings and Balls
- ◆ 302 Stainless Steel Flingers and Retainers
- ◆ Setscrew Lock - Wide Inner Ring
- ◆ Factory Filled USDA H1 Lubricant Meets FDA Regulation 178.3570 Requirement for Incidental Contact with Food
- ◆ 304 Stainless Steel Setscrews
- ◆ Anti Rotation Pin
- ◆ Ultradur Glass Reinforced PBT Thermoplastic Housing
- ◆ Tensile Strength 16700 psi at Room Temperature
- ◆ Stainless Steel Bushings in All Bolt Holes
- ◆ Stainless Steel Insert for Zerk Threads
- ◆ Stainless Steel Zerk
- ◆ Moisture Resistant
- ◆ Corrosion Resistant
- ◆ Grooved for Composite Dust Caps on One Side, See Page O-31
- ◆ Smooth Surface with No Ribs for Easy Cleaning

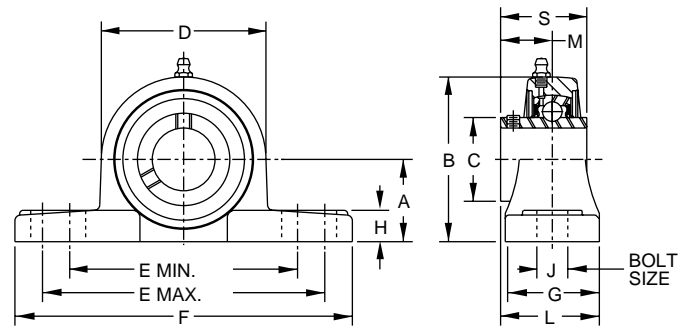

SHAFT SIZE	A	B	C	D	E MIN.	E MAX.	F	G	H	J	L	M	S	Wt. Lbs.
1/2, 5/8	1-5/16	2-19/32	1.142	2-17/32	3-5/8	3-7/8	5	1-1/2	9/16	3/8	1-15/32	0.720	1.220	0.7
3/4	1-5/16	2-19/32	1.142	2-17/32	3-5/8	3-7/8	5	1-1/2	9/16	3/8	1-15/32	0.720	1.220	0.7
7/8, 1	1-7/16	2-25/32	1.339	2-23/32	4-1/32	4-1/4	5-17/32	1-1/2	9/16	3/8	1-17/32	0.780	1.343	0.7
1-1/8, 1-3/16, 1-1/4S	1-11/16	3-5/16	1.587	3-1/4	4-17/32	4-27/32	6-13/32	1-13/16	11/16	1/2	1-25/32	0.874	1.500	1.2
1-1/4, 1-3/8, 1-7/16	1-7/8	3-23/32	1.890	3-11/16	4-27/32	5-5/32	6-5/8	1-7/8	23/32	1/2	1-61/64	1.000	1.689	1.6
1-1/2	1-15/16	3-31/32	2.087	4-3/32	5-1/4	5-9/16	7-1/4	2-1/8	25/32	1/2	2-1/4	1.189	1.937	2.3

Part Numbers are specified by "PB251CTW" and Bore Size. Example: PB251CTW x 3/4.
For replacement inserts use B250TW Bearing Inserts, O-28.

For Load Ratings, See page O-28 & O-29.

Tapped Base Pillow Block TPB250CTW

Features: (Same as Above)

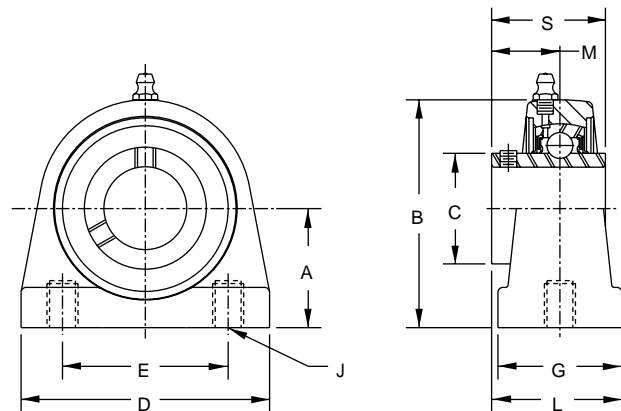

FOR LUBRICATION AND INSTALLATION INSTRUCTIONS - REFER TO SECTION R

SHAFT SIZE	A	B	C	D	E	G	J - TAPPED HOLES	L	M	S	Wt. Lbs.
1/2, 5/8	1-5/16	2-19/32	1.142	2-7/8	2	1-11/32	3/8-16NC X 1/2	1-13/32	0.720	1.220	0.6
3/4	1-5-16	2-19/32	1.142	2-7/8	2	1-11/32	3/8-16NC X 1/2	1-13/32	0.720	1.220	0.6
7/8, 1	1-7/16	2-29/32	1.339	3	2	1-9/16	3/8-16NC X 1/2	1-35/64	0.780	1.343	0.7
1-1/8, 1-3/16, 1-1/4S	1-11/16	3-5/16	1.587	3-31/32	3	1-21/32	7/16-14NC X 1/2	1-23/32	0.874	1.500	1.1
1-1/4, 1-3/8, 1-7/16	1-7/8	3-3/4	1.890	4-11/32	3-1/4	1-7/8	1/2-13NC X 5/8	1-15/16	1.000	1.689	1.6
1-1/2	1-15/16	3-31/32	2.087	4-23/32	3-1/2	1-29/32	1/2-13NC X 5/8	2-1/8	1.189	1.937	2.2

Part Numbers are specified by "TPB250CTW" and Bore Size. Example: TPB250CTW x 1.
For replacement inserts use B250TW Bearing Inserts, O-28.

For Load Ratings, See page O-28 & O-29.

Certified prints are available upon request

† Dimensions shown are for reference only.

CleanLine Plus™ Thermoplastic

Composite Mounted Bearings - 4 Bolt Flange Block FB250CTW

Features:

- ◆ 440 Stainless Steel Rings and Balls
- ◆ 302 Stainless Steel Flingers and Retainers
- ◆ Setscrew Lock - Wide Inner Ring
- ◆ Factory Filled USDA H1 Lubricant Meets FDA Regulation 178.3570 Requirement for Incidental Contact with Food
- ◆ 304 Stainless Steel Setscrews
- ◆ Anti Rotation Pin
- ◆ Ultradur Glass Reinforced PBT Thermoplastic Housing
- ◆ Tensile Strength 16700 psi at Room Temperature
- ◆ Stainless Steel Bushings in All Bolt Holes
- ◆ Stainless Steel Insert for Zerk Threads
- ◆ Stainless Steel Zerks
- ◆ Moisture Resistant
- ◆ Corrosion Resistant
- ◆ Grooved for Composite Dust Caps on One Side, See Page O-31
- ◆ Smooth Surface with No Ribs for Easy Cleaning

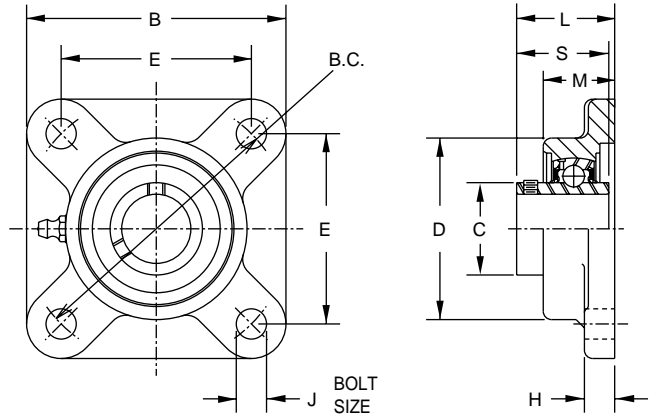

SHAFT SIZE	B	B.C.	C	D	E	H	J	L	M	S	Wt. Lbs.
1/2, 5/8	3-3/8	3-17/32	1.142	2-17/32	2-1/2	17/32	3/8	1-23/64	1-3/32	1.220	0.7
3/4	3-3/8	3-17/32	1.142	2-17/32	2-1/2	17/32	3/8	1-23/64	1-3/32	1.220	0.7
7/8, 1	3-3/4	3-57/64	1.339	2-3/4	2-3/4	9/16	3/8	1-29/64	1-1/8	1.343	0.8
1-1/8, 1-3/16, 1-1/4S	4-7/32	4-19/32	1.587	3-1/8	3-1/4	9/16	3/8	1-5/8	1-1/4	1.500	1.1
1-1/4, 1-3/8, 1-7/16	4-5/8	5-1/8	1.890	3-17/32	3-5/8	5/8	7/16	1-27/32	1-23/64	1.689	1.6
1-1/2	5-1/8	5-21/32	2.087	3-15/16	4	11/16	1/2	2-3/32	1-7/16	1.937	2.3

Part Numbers are specified by "FB250CTW" and Bore Size. Example: FB250CTW x 3/4.
For replacement inserts use B250TW Bearing Inserts, O-28.

For Load Ratings, See page O-28 & O-29.

2 Bolt Flange Blocks FB260CTW

Features: (Same as Above)



FOR LUBRICATION AND INSTALLATION INSTRUCTIONS - REFER TO SECTION R

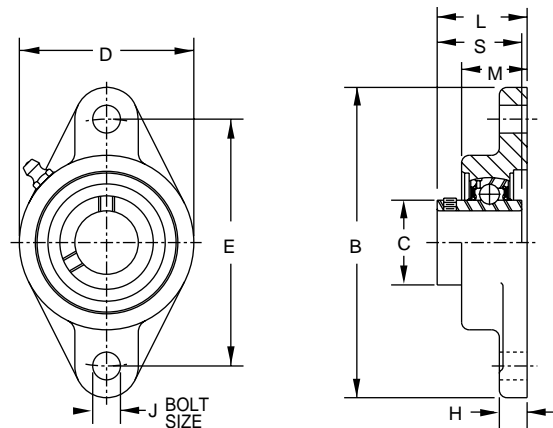

SHAFT SIZE	B	C	D	E	H	J	L	M	S	Wt. Lbs.
1/2, 5/8	4-7/16	1.142	2-9/16	3-17/32	17/32	3/8	1-5/16	1-3/64	1.220	0.6
3/4	4-7/16	1.142	2-9/16	3-17/32	17/32	3/8	1-5/16	1-3/64	1.220	0.6
7/8, 1	5-5/32	1.339	2-3/4	3-57/64	9/16	3/8	1-27/64	1-7/64	1.343	0.7
1-1/8, 1-3/16, 1-1/4S	5-13/16	1.587	3-5/32	4-19/32	9/16	3/8	1-37/64	1-13/64	1.500	1.0
1-1/4, 1-3/8, 1-7/16	6-15/32	1.890	3-17/32	5-1/8	5/8	7/16	1-3/4	1-17/64	1.689	1.4
1-1/2	6-15/16	2.087	3-15/16	5-21/32	11/16	1/2	2-1/32	1-3/8	1.937	2.0

Part Numbers are specified by "FB260CTW" and Bore Size. Example: FB260CTW x 3/4.
For replacement inserts use B250TW Bearing Inserts, O-28.

For Load Ratings, See page O-28 & O-29.

† Dimensions shown are for reference only.

Certified prints are available upon request

CleanLine Plus™ & UltraPlus Bearing Inserts

B250TW Stainless Steel Bearings

Features:

- ◆ 440 Stainless Steel Rings and Balls
- ◆ 302 Stainless Steel Retainers
- ◆ Setscrew Lock - Wide Inner Ring
- ◆ Factory Filled USDA HI Lubricant Meets FDA Regulation 178.3570 Requirement for Incidental Contact with Food
- ◆ Silicone Seals with 302 Stainless Steel Flingers
- ◆ Lube Groove for Relubrication. (Housing Groove Not Required)
- ◆ 304 Stainless Steel Setscrews
- ◆ Anti Rotation Pin

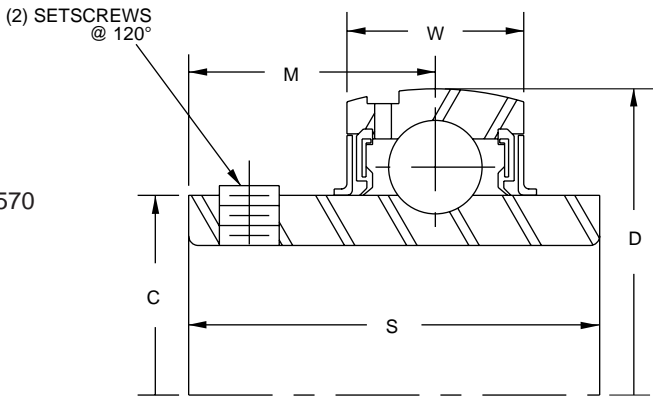

SHAFT SIZE	C	D	M	S	W	SETSCREW	Wt. Lbs.
1/2, 5/8	1.142	1.8504	0.720	1.220	0.669	1/4-28 UNF	0.4
3/4	1.142	1.8504	0.720	1.220	0.669	1/4-28 UNF	0.4
7/8, 1	1.339	2.0472	0.780	1.343	0.669	1/4-28 UNF	0.5
1-1/8, 1-3/16, 1-1/4S	1.587	2.4409	0.874	1.500	0.748	1/4-28 UNF	0.7
1-1/4, 1-3/8, 1-7/16	1.890	2.8346	1.000	1.689	0.787	5/16-24 UNF	1.0
1-1/2	2.087	3.1496	1.189	1.937	0.827	5/16-24 UNF	1.5
1-11/16, 1-3/4	2.252	3.3465	1.189	1.937	0.866	5/16-24 UNF	1.6
1-15/16	2.433	3.5433	1.283	2.031	0.906	3/8-24 UNF	1.8

CleanLine™ Stainless Steel Bearing Ratings - Series B250TW

BEARING RADIAL LOAD CAPACITY (POUNDS) FOR 500 HOURS L-10 LIFE (2500 HOURS AVERAGE LIFE) AND STEADY LOAD CONDITIONS										
SHAFT SIZE (INCHES) 100, 200 SERIES	BASIC DYNAMIC RATING, C* (POUNDS)	BASIC STATIC RATING, Co** (POUNDS)	BEARING SPEED (RPM)							
			100	500	1,000	1,500	2,000	2,500	3,000	3,500
1/2 to 5/8	2200	1390	1,530	890	710	620	560	520	490	470
3/4	2200	1390	1,530	890	710	620	560	520	490	470
7/8 to 1	2430	1570	1,680	990	780	680	620	580	540	520
1-1/8 to 1-1/4S	3350	2250	2,320	1,360	1080	940	860	790	750	710
1-1/4 to 1-7/16	4430	3060	3,070	1,800	1430	1250	1130	1050	990	
1-1/2	5640	3990	3,910	2,290	1810	1590	1440	1340	1260	
1-11/16 to 1-3/4	5640	3990	3,910	2,290	1810	1590	1440	1340		
1-7/8 to 1-15/16	6060	4450	4,200	2,460	1950	1700	1550	1440		

* Radial load for an L-10 rating life of 1,000,000 revolutions.
 ** Radial load rating for stationary or very low speed operation.

For ultimate life, snug fit or light press fit on shaft should be used.
 Recommended operating temperature range: 0 to +225 deg F.
 For applications not covered in the rating tables, consult the factory.
 Ratings are based on ISO 281.

Maximum Recommended Speeds:
 1/2 to 1-1/4S 3,500 RPM
 1-1/4 to 1-1/2 3,000 RPM
 1-5/8 to 1-15/16 2,500 RPM

TO MODIFY THE ABOVE RATINGS FOR OTHER L-10 LIFE REQUIREMENTS OR FOR SHOCK LOADS MULTIPLY THE ABOVE RATINGS BY THE FACTOR FROM THIS CHART														
MODIFICATION FACTORS FOR L-10 SERVICE LIFE AND LOAD CONDITIONS:														
LOAD CONDITIONS	L-10 LIFE (HOURS)													
	500	700	1,000	1,500	2,000	3,000	4,000	5,000	7,000	10,000	15,000	20,000	30,000	50,000
Steady Load	1.00	.894	.794	.694	.630	.550	.500	.464	.415	.368	.322	.292	.255	.215
Light Shock	.90	.804	.715	.624	.567	.495	.450	.418	.373	.331	.290	.263	.230	.194
Moderate Shock	.70	.626	.556	.485	.441	.385	.350	.325	.290	.258	.225	.205	.179	.151

Certified prints are available upon request



Load Ratings

CleanLine Plus™ Load Ratings

BREAKING POINT TESTS OF COMPOSITE HOUSINGS AT ROOM TEMPERATURE (75 F.)						
	MODE OF LOAD	BREAKING STRENGTH (POUNDS)				
		1/2 to 3/4	7/8 to 1	1-1/8 to 1-1/4S	1-1/4 to 1-7/16	1-1/2
PB251CTW		2000	3100	2800	2900	2900
		1700	2200	2400	2400	2500
		1100	1800	1300	1700	1900
FB250CTW		2900	2900	3800	4200	4300
		2300	2700	4000	4200	4300
		730	750	760	790	850
FB260CTW		2500	2600	3700	3800	3900
		2500	3100	3000	3100	3200
		1900	2500	3200	3300	3400
TPB250CTW		1800	1900	2300	2700	2700
		1500	1600	1500	1800	2000
		670	640	1100	1800	2200

Recommended operating temperature of composite housings is 20 to 230 deg F.
 Housing strength varies with operating temperature, and this must be considered in the selection and application of composite bearing units.

CleanLine UltraPlus™ Mounted Bearing

Accessories - Clearance Spacers

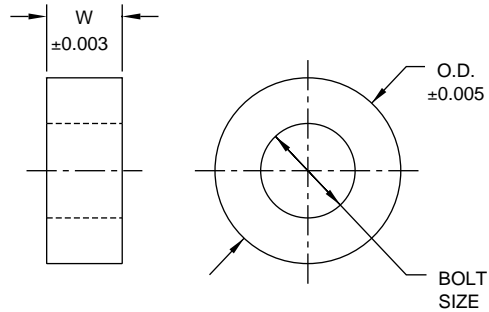
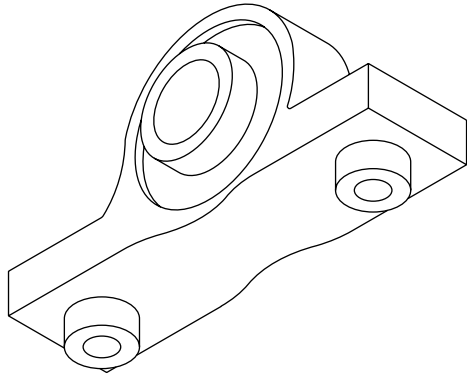

Clearance spacers are an excellent method of adding space between the mounted bearing and its mounting surface.

Clearance spacers minimize the surface contact area between the mounted bearing and its mounting surface to reduce potential bacterial growth areas.

Clearance spacers provide space for cleaning brushes to be used during sanitation processes. The spacers allow accessibility when cleaning by high-pressure washing or circulation of flowing chemical solutions, cleaning liquids and water rinses.

316 STAINLESS STEEL Clearance Spacers

Bolt Size	Spacer No.	O.D.	W
1/4	8471601286	0.625	0.375
5/16	8471601287	0.688	0.375
3/8	8471601288	0.812	0.375
7/16	8471601289	0.922	0.375
1/2	8471601290	0.969	0.375
5/8	8471601291	1.312	0.375

Order (1) spacer for each mounting hole required.
Consult factory for additional sizes available.

Suitable for:
CleanLine Pharmaceutical
CleanLine UltraPlus
CleanLine Plus
CleanLine Gear Drives

CleanLine UltraPlus™ Mounted Bearing

Accessories - Protective Caps

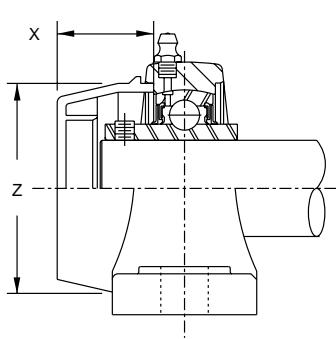

CLOSED PILLOW BLOCK UNITS

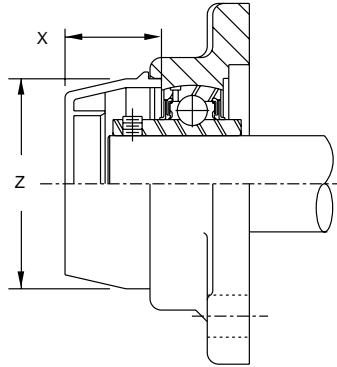

CLOSED FLANGE UNITS

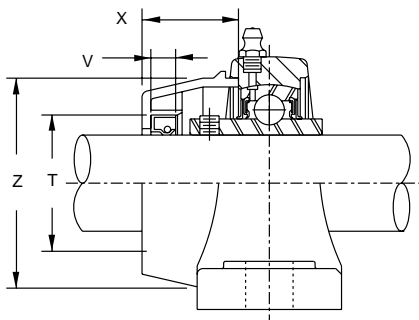

OPEN PILLOW BLOCK UNITS

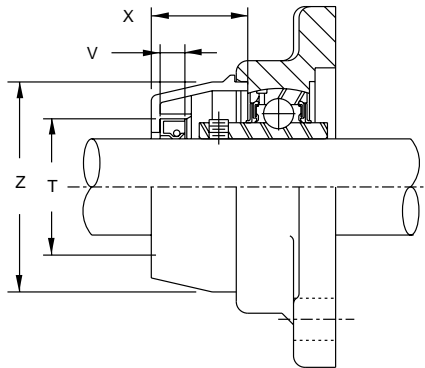

OPEN FLANGE UNITS



PROTECTIVE CAPS AND SEALS										
SHAFT SIZE	T	V	X	Z	Closed Cap		Open Cap		Seal for Open Cap	
					Description	Part Number	Description	Part Number	Description	Part Number
1/2	1.260	0.28	29/32	1-31/32	CPCCx3/4	1540101016	CPOCx3/4	1540101007	CPSEALx1/2	1745011004
5/8									CPSEALx5/8	1745011005
3/4									CPSEALx3/4	1745011006
7/8	1.457	0.28	1	2-5/32	CPCCx1	1540101017	CPOCx1	1540101008	CPSEALx7/8	1745011019
1									CPSEALx1	1745011007
1-1/8									CPSEALx1-1/8	1745011008
1-3/16	1.654	0.28	1-3/16	2-1/2	CPCCx1-3/16	1540101018	CPOCx1-3/16	1540101009	CPSEALx1-3/16	1745011009
1-1/4S									CPSEALx1-1/4S	1745011010
1-1/4									CPSEALx1-1/4	1745011011
1-3/8	1.850	0.28	1-1/4	2-15/16	CPCCx1-7/16	1540101019	CPOCx1-7/16	1540101010	CPSEALx1-3/8	1745011012
1-7/16									CPSEALx1-7/16	1745011013
1-1/2									CPSEALx1-1/2	1745011014

PROTECTIVE CAPS AND SEALS ARE SUITABLE FOR BOTH STAINLESS STEEL AND THERMOPLASTIC COMPOSITE BEARINGS
CAPS AND SEALS ARE SOLD SEPARATELY. ORDER BY DESCRIPTION OR PART NUMBERS SHOWN

CleanLine Plus™ Models CPAD3, CPAD4, CPAD5

Features

- ◆ Cast aluminum housing with Platinum Plus finish designed to resist corrosion and provide rigid gear and bearing support.
- ◆ Stainless steel or chrome plated shaft provide resistance to corrosion.
- ◆ Precision ball bearings to accommodate higher operating speeds.
- ◆ Spiral bevel gearing to assure low noise level at higher operating speeds.
- ◆ High Pressure Seals with V-Rings
- ◆ Factory filled with USDA H1 lubricant for application service life.
- ◆ Universal mounting (5 surfaces) to assure maximum design flexibility.
- ◆ BISSC Certification Optional



Rating Table

INPUT RPM†		MODEL CPAD4 RATIO		MODEL CPAD5 RATIO		MODEL CPAD3 RATIO	
		1:1	2:1Δ	1:1	2:1Δ	1:1	2:1Δ
3600	INPUT HORSEPOWER	1.810	.525	4.310	2.120	10.250	3.820
	OUTPUT TORQUE IN. LBS.	31.700	18.400	75.500	74.200	179.560	133.800
2400	INPUT HORSEPOWER	1.240	.356	2.950	1.450	7.100	2.620
	OUTPUT TORQUE IN. LBS.	32.500	18.700	77.400	76.100	186.400	137.600
1750	INPUT HORSEPOWER	.913	.262	2.190	1.070	5.270	1.960
	OUTPUT TORQUE IN. LBS.	32.900	18.900	78.700	77.200	189.700	141.000
1150	INPUT HORSEPOWER	.609	.176	1.470	.720	3.550	1.320
	OUTPUT TORQUE IN. LBS.	33.400	19.300	80.300	78.600	194.800	144.400
850	INPUT HORSEPOWER	.457	.131	1.100	.540	2.670	.990
	OUTPUT TORQUE IN. LBS.	33.900	19.500	81.300	79.400	198.000	146.800
690	INPUT HORSEPOWER	.374	.108	.900	.440	2.190	.810
	OUTPUT TORQUE IN. LBS.	34.200	19.700	81.900	80.000	200.100	148.200
400	INPUT HORSEPOWER	.220	.064	.530	.260	1.300	.480
	OUTPUT TORQUE IN. LBS.	34.700	20.000	83.300	81.200	204.800	151.200
200	INPUT HORSEPOWER	.112	.033	.270	.130	.670	.250
	OUTPUT TORQUE IN. LBS.	35.100	20.300	84.700	82.400	209.400	154.400
100	INPUT HORSEPOWER	.057	.016	.140	.070	.340	.130
	OUTPUT TORQUE IN. LBS.	35.600	20.500	85.800	83.200	212.900	156.600

†For Higher Input Speeds Consult Factory

Δ2:1 Ratio Has Plated Pinion Shafts

Standard Styles Available

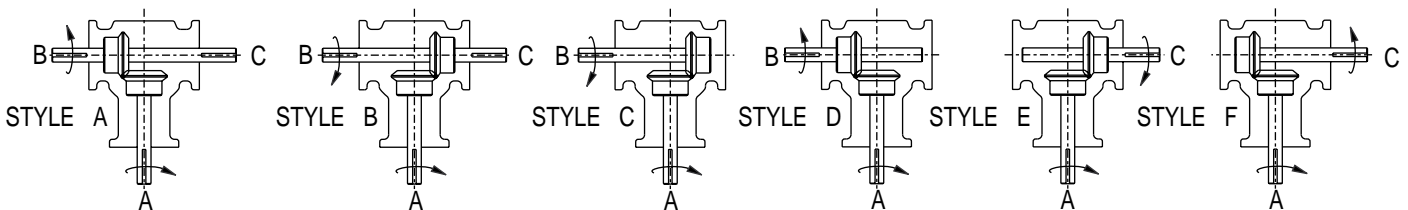

CONSULT FACTORY FOR VERTICAL SHAFT LUBRICATION RECOMMENDATIONS
 INPUT SHAFT CAN BE ROTATED IN EITHER DIRECTION

CleanLine Plus™ Models CPAD3, CPAD4, CPAD5

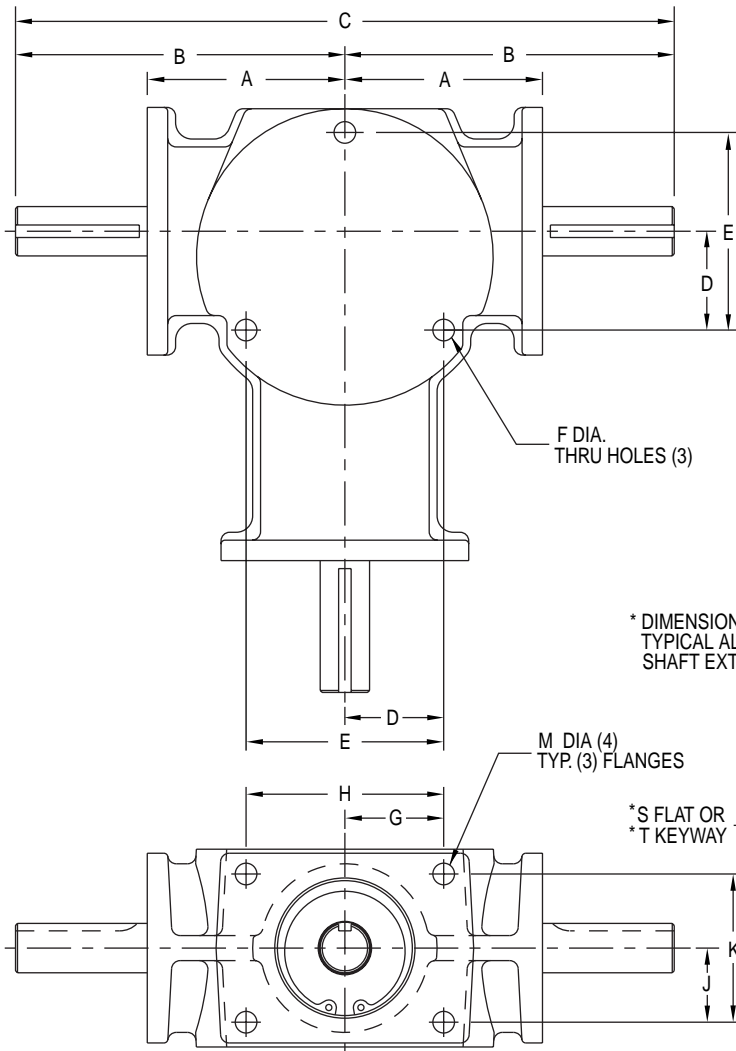

* DIMENSIONS TYPICAL ALL SHAFT EXTENSIONS

ALLOWABLE SHAFT LOADS ALL RATIOS AND SHAFTS

MODEL NO.	OVERHUNG LOAD**	THRUST LOAD
AD 3	100 lbs.	200 lbs.
AD 4	25 lbs.	50 lbs.
AD 5	50 lbs.	100 lbs.

** ASSUMES LOAD AT MIDPOINT OF SHAFT EXTENSION

FOR LUBRICATION AND INSTALLATION INSTRUCTIONS - REFER TO SECTION R

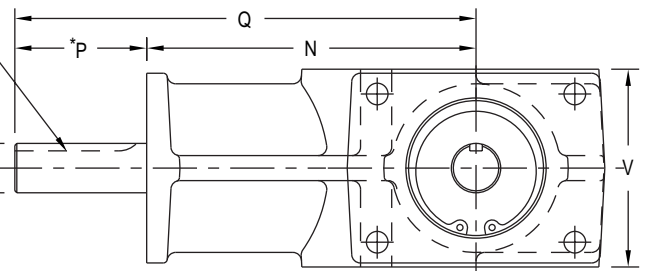

SHIPPING WEIGHTS

MODEL CPAD38-1/4 lbs.
MODEL CPAD41/2 lb.
MODEL CPAD52 lbs.

DIMENSIONS SHOWN ARE FOR REFERENCE ONLY.
CERTIFIED PRINTS ARE AVAILABLE UPON REQUEST.

INPUT SHAFT CAN BE ROTATED IN EITHER DIRECTION

MODEL NO.	A	B	C	D	E	F	G	H	J	K	M
CPAD3	3	5	10	1.500	3.000	21/64	1.500	3.000	1.125	2.250	21/64
CPAD4	1-3/8	1-63/64	3-61/64	.656	1.312	17/64	.594	1.188	.438	.875	11/64
CPAD5	2-1/8	3-5/8	7-1/4	.937	1.875	17/64	.937	1.875	.687	1.375	17/64

MODEL NO.	N	P	Q	R	S	T	V
CPAD3	5	2	3.005 7	.750/.749	—	3/16 X 3/32 1-9/16 EFF. LGTH.	3.005/3.000
CPAD4	2-5/32	19/32	2-3/4	.3745/.3740	1/32 DEEP	.60 Eff. Flat	1.255/1.250
CPAD5	3-1/4	1-1/2	2.005 4-3/4	.6245/.6240	—	3/16 X 3/32 1-7/32 EFF. LGTH.	2.005/2.000

CleanLine™ Gear Drives



CleanLine™ High Efficiency Gear Drives

Features:

- ◆ FDA/USDA Approved White Acrylic Paint
- ◆ FDA/USDA Approved Stainless Steel Paint Optional
- ◆ 303 Stainless Steel Output Shafts
- ◆ Stainless Steel Hardware and Nameplate
- ◆ BISSC Certification Optional
- ◆ Available in All Standard Models of Helical Bevel, Helical Worm, Helical Parallel & Helical InLine
- ◆ Spring Loaded Double Lip Seals with V-Rings

Refer to Sections I,J,K and L for Ratings and Dimensions



CleanLine™ Worm & Bevel Gear Drives

Features:

- ◆ FDA/USDA Approved White Acrylic Paint
- ◆ FDA/USDA Approved Stainless Steel Paint Optional
- ◆ 303 Stainless Steel Output Shafts
- ◆ Stainless Steel Hardware and Nameplate
- ◆ BISSC Certification Optional
- ◆ Available in All Standard Models
- ◆ Spring Loaded Double Lip Seals with V-Rings
- ◆ Components in Stock for Worm Gear Series 130 thru 320 (Model # Ending in 1, 2, 3, 4, 5, 6)
- ◆ Components In Stock for Bevel Gear Models M3 thru 66
- ◆ **Most Popular Models Available in 5 Days or Less!**

Refer to Sections B and D for Ratings and Dimensions

Modified and Custom Designs

If you have looked through this catalog and do not see exactly what you need, Hub City has the capability and engineering expertise to design and produce a special drive.

Capabilities range from flange and shaft modifications, to custom housing dimensions.

Consult the factory or your Hub City representative with your specifications.